



EO[®] Ermeto Original Valves



Visual index Non return valves

RHD / p. P13

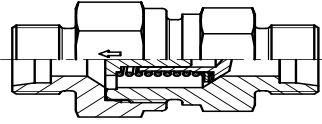

EO 24° cone end / EO 24° cone end

RHV-R-ED / p. P14

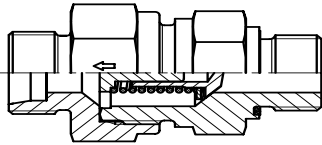

EO 24° cone end /
Male BSPP thread – ED-seal (ISO 1179)

RHZ-R-ED / p. P15

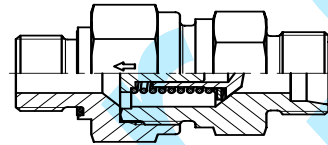

Male BSPP thread – ED-seal (ISO 1179) /
EO 24° cone end

RHV-M-ED / p. P16

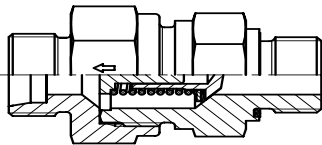

EO 24° cone end /
Male metric thread – ED-seal (ISO 9974)

RHZ-M-ED / p. P17

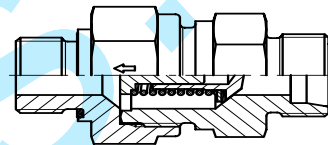

Male metric thread – ED-seal (ISO 9974) /
EO 24° cone end

RHDI / p. P18

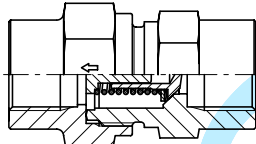

Female BSPP thread (ISO 1179-1) /
Female BSPP thread (ISO 1179-1)

RVP / p. P19

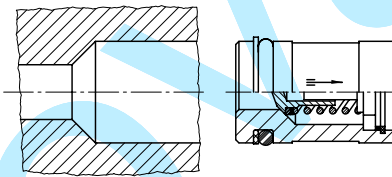

Non return valve cartridge

I-TL / p. P20

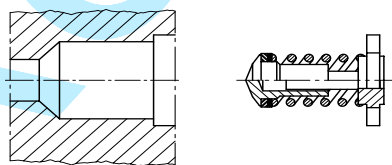

Internal parts of non return valve

Visual index Non return valves with O-Lok® connections

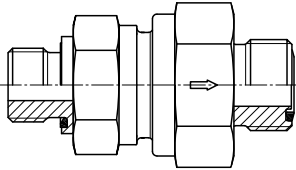
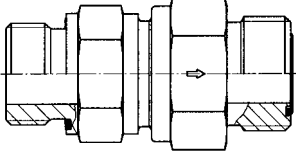
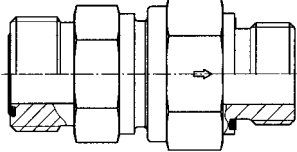
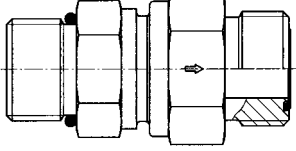
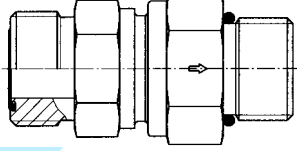
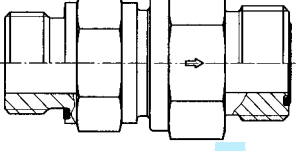
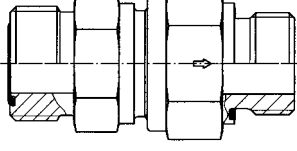
<p>RHDMLOS / p. P22</p>  <p>O-Lok® ORFS end / O-Lok® ORFS end</p>	
<p>RHV42EDMLOS / p. P23</p>  <p>Male BSPP thread – ED-seal (ISO 1179) / O-Lok® ORFS end</p>	<p>RHZ42EDMLOS / p. P24</p>  <p>O-Lok® ORFS end / Male BSPP thread – ED-seal (ISO 1179)</p>
<p>RHV50MLOS / p. P25</p>  <p>Male UN/UNF thread– O-ring (ISO 11926) / O-Lok® ORFS end</p>	<p>RHZ50MLOS / p. P26</p>  <p>O-Lok® ORFS end / Male UN/UNF thread– O-ring (ISO 11926)</p>
<p>RHV82EDMLOS / p. P27</p>  <p>Male metric thread – ED-seal (ISO 9974) / O-Lok® ORFS end</p>	<p>RHZ82EDMLOS / p. P28</p>  <p>O-Lok® ORFS end / Male metric thread – ED-seal (ISO 9974)</p>

Visual index Non return valves with Triple-Lok® connections

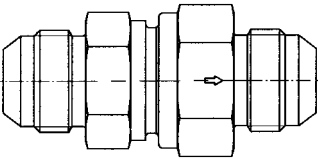
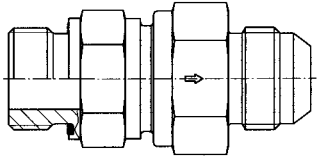
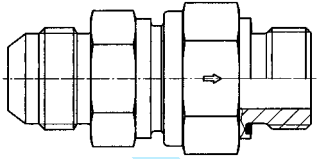
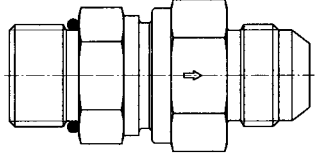
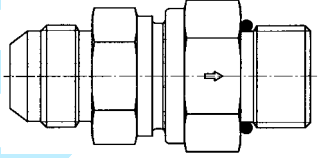
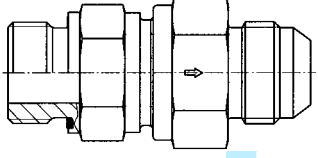
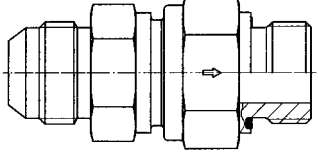
<p>RHDMTXS / p. P29</p>  <p>Triple-Lok® 37° flare end / Triple-Lok® 37° flare end</p>	
<p>RHV42EDMXS / p. P30</p>  <p>Male BSPP thread – ED-seal (ISO 1179) / Triple-Lok® 37° flare end</p>	<p>RHZ42EDMXS / p. P31</p>  <p>Triple-Lok® 37° flare end / Male BSPP thread – ED-seal (ISO 1179)</p>
<p>RHV50MXS / p. P32</p>  <p>Male UN/UNF thread – O-ring (ISO 11926) / Triple-Lok® 37° flare end</p>	<p>RHZ50MXS / p. P33</p>  <p>Triple-Lok® 37° flare end / Male UN/UNF thread – O-ring (ISO 11926)</p>
<p>RHV82EDMXS / p. P34</p>  <p>Male metric thread – ED-seal (ISO 9974) / Triple-Lok® 37° flare end</p>	<p>RHZ82EDMXS / p. P35</p>  <p>Triple-Lok® 37° flare end / Male metric thread – ED-seal (ISO 9974)</p>

Visual index 2/2-way ball valves Series KH

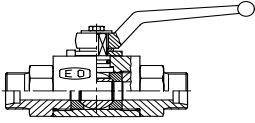
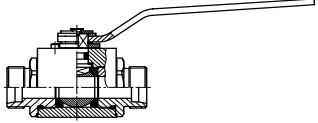
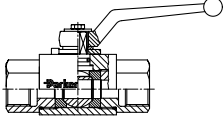
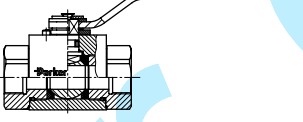
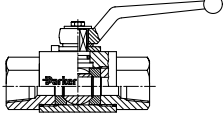
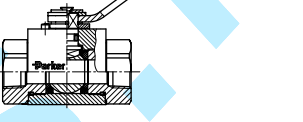
 <p>KH (S) p. P36</p> <p>EO 24° cone end / EO 24° cone end</p>	 <p>KH (71) p. P37</p> <p>EO 24° cone end / EO 24° cone end</p>
 <p>KH-BSPP (S) p. P38</p> <p>Female BSPP thread (ISO 1179-1) / Female BSPP thread (ISO 1179-1)</p>	 <p>KH-BSPP (71) p. P39</p> <p>Female BSPP thread (ISO 1179-1) / Female BSPP thread (ISO 1179-1)</p>
 <p>KH-NPT (S) p. P40</p> <p>Female NPT thread (SAE 476) / Female NPT thread (SAE 476)</p>	 <p>KH-NPT (71) p. P41</p> <p>Female NPT thread (SAE 476) / Female NPT thread (SAE 476)</p>

Visual index 3/2-way ball valves

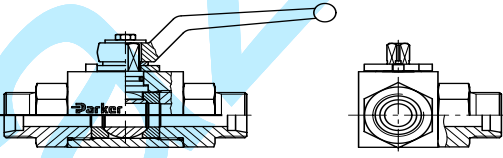
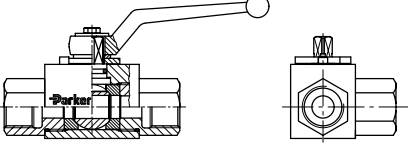
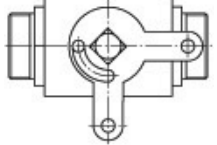
 <p>KH 3/2 (S) p. P42</p> <p>EO 24° cone end / EO 24° cone end / EO 24° cone end</p>
 <p>KH 3/2-BSPP(S) p. P43</p> <p>Female BSPP thread (ISO 1179-1) / Female BSPP thread (ISO 1179-1) / Female BSPP thread (ISO 1179-1)</p>
 <p>KH p. P44</p> <p>Locking Devices for 2/2 Way and Multiway ball valves</p>



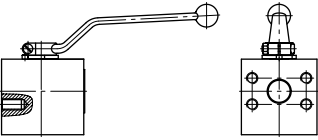
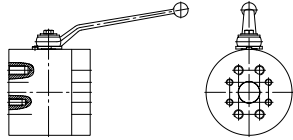
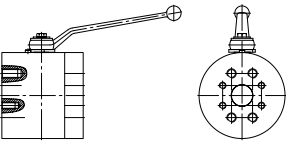
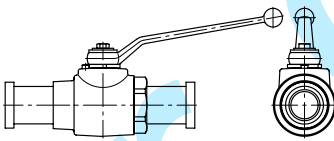
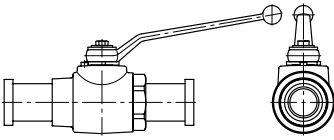
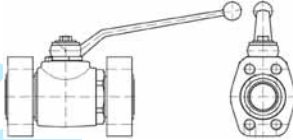
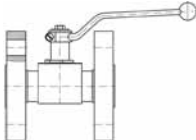
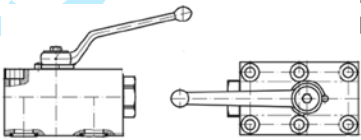

Visual index SAE ball valves/Ball valves for block structure

 <p>KH-B1V-S p. P45</p> <p>Ball valve with SAE Flange connection</p>	 <p>KH-B2V-S p. P46</p> <p>Ball valve with SAE Flange connection</p>
 <p>KH-B3V-S p. P47</p> <p>Ball valve with SAE Flange connection</p>	 <p>KH-A-S p. P48</p> <p>Ball valve with SAE Flange connection</p>
 <p>KH-A-S-71 p. P49</p> <p>Ball valve with SAE Flange adapter connection</p>	 <p>KH-B4V-S p. P50</p> <p>Ball valve with SAE Flange connection ISO 6162 (1/2)</p>
 <p>KHB5V-S p. P51</p> <p>Ball valve with Flange connection DIN EN 1092-1</p>	 <p>KHBLOCK p. P52</p> <p>2/2-way ball valve for block structure</p>

KONVAL

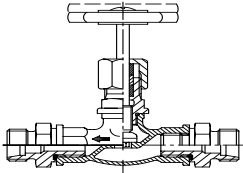
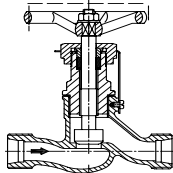
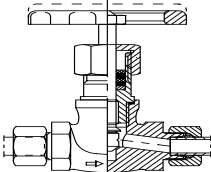
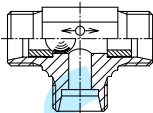
Visual index shut off valves and Line Rupture Valves “LRV”

 <p>DV p. P53</p> <p>EO 24° cone end / EO 24° cone end</p>	 <p>LD p. P54</p> <p>EO 24° cone end / EO 24° cone end</p>
 <p>VDHA p. P55</p> <p>EO tube end / EO tube end</p>	 <p>WV p. P56</p> <p>EO 24° cone end / EO 24° cone end / EO 24° cone end</p>
 <p>ELA/ELAE p. P57/P58</p> <p>Air-bleed valves</p>	

KOVAN

Range of non return valves, alternating valves and hand-operated shut off valves

Non-return valves with nominal pressure ratings up to PN 420 bar:

- with tube connection both ends: RHD
- with tube connection to male stud: RHV/RHZ
- with female thread both ends: RHD1
- valve cartridges: RVP
- valve internal parts: I-TL
- leakage rate hydraulic testing under test pressure: 1 drop per minute

Alternating valves:

- for nominal pressure ratings up to PN 160 WV
- leakage rate hydraulic testing under test pressure: 20 drops per minute

Shut-off valves:

- for high pressure ratings up to PN 630 bar VDHA

Design:

1. For materials, permissible working pressures, temperatures, flow medium torques for male studs etc. see relevant pages of the catalogue.
2. Tube connection ends must be assembled according to the Parker EO/EO-2 assembly instructions.
3. The valve bodies must be held rigidly during assembly of the tube connection ends.
4. Test pressures for non return valves: PN in conformance with O.D. information see chapter C.
5. Pressure drop values please see p. C12 and diagrams.

Caution!

Please note the admissible pressure ratings for the EO-tube ends.

Range of quarter turn ball valves

Quarter turn Hand-operated ball valves:

- for high pressure ratings up to PN 500 bar KH
- leakage rate hydraulic testing under test pressure: 0 drops per minute

The pressure specification PN for hand-operated shut-off valves and quarter turn ball valves applies to the design factor 1,5 (according DIN 3230 T5 and ISO 5208).

Steel

Materials:

Body made of steel, Cr(VI)-free galvanized or bronzed (coating DIN 50938-FE//A/T4), ball of hard chrome plated carbon steel, stem of zinc plated steel.

Seals:

Ball seat of POM (e. g. Delrin), stem seal of NBR (e. g. Perbunan).

Applications:

Suitable for petroleum-based hydraulic fluid, lubricants and fuel oil up to 500 bar.
For applications with air suitable up to 100 bar.

Temperature range:

-10 up to +100 °C.

Stainless Steel

Materials:

Body made of stainless steel, ball of stainless steel, stem and connectors of stainless steel.

Seals:

Ball seat of POM (e. g. Delrin), stem seal of NBR (e. g. Perbunan), DOZ from function nut FKM (e. g. FKM).

Applications:

Suitable for petroleum-based hydraulic fluid, lubricants and fuel oil.
For applications with air suitable up to 100 bar.

Temperature range:

-30 up to +100 °C.

Perbunan = registered trademark of Bayer

Notes:

To assess the suitability of valves for specific applications, please advise us of the exact specification of the medium to be used, max. working pressure incl. pressure peaks, temperature and frequency of valve operations. If water is used, indicate type of water or additives, if any.

RHD/V/Z non return valve

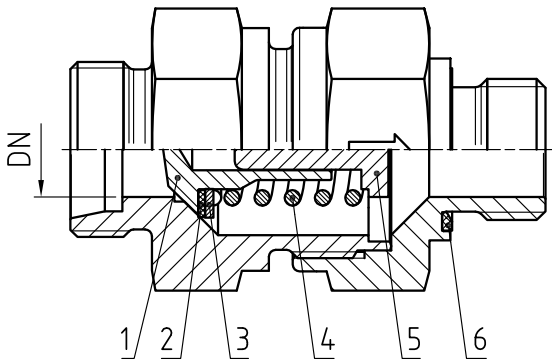

Design with sealing edge:
Size 06L and 08L / 06S and 08S
and all sizes in stainless steel with a PTFDE sealing disc.

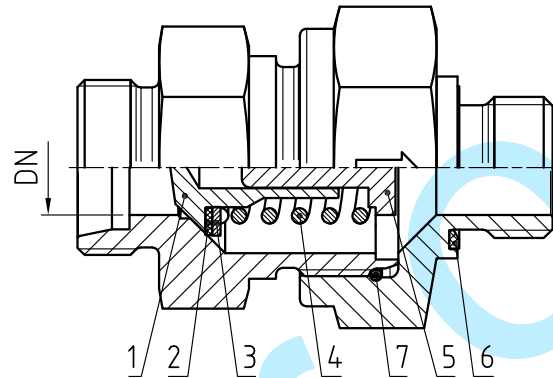

Design with O-ring (item. 7):
Sizes 10L, 12L, 15L, 18L, 22L, 28L, 35L and 42L
as well as 10S, 12S, 14S, 16S, 20S, 25S, 30S and 38S with a
sealing disc out of NBR (steel) or FKM (stainless steel).

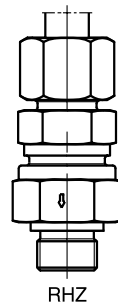
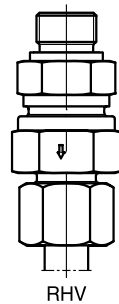
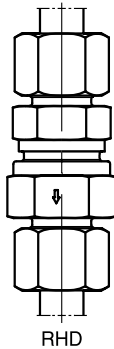

- 1: poppet
 - 2: sealing disc
 - 3: cover disc
 - 4: spring
 - 5: passage disc
 - 6: Eolastic-sealing
 - 7: O-ring
- DN = Nominal diameter (mm)

Characteristics:

Poppet check valve with a 90° valve seat with an elastomere sealing disc. Poppet stop for controlled valve opening. Damped opening action to minimize shock and noise. No reduction of cross section. Maximum flow velocity not more than 8 m/sec. Sealing of male stud thread by Eolastic soft seal with types RHV and RHZ.

Opening pressure:

Standard 1 bar (on request also 0.2, 0.5, 2, 3, 4, 5 and 6 bar are available; please specify on order). For working pressure see appropriate tables. Cracking pressure tolerance: ± 20 %.

Material:

- Steel zinc-plated (CF Cr[VI]-free), seals in NBR (e.g. Perbunan), or (FKM) on request.

Perbunan = registered trademark of Bayer

- Stainless steel valves have FKM as standard. (Up to 3 bar cracking pressure)

- Brass-valves (CuZn35Ni2 2.0540) with internals (1.4571) available on request. (Up to 3 bar cracking pressure)

Assembly:

See assembly instructions for EO/EO 2 connections. Non-return valves are all packaged against contamination.

Media:

Hydraulic oil, low flammability hydraulic fluids (except for types HFC: for HFD types; FKM seals are necessary). Air pressure tested (please indicate on order). Not suitable for steam, combustible/explosive gases, or oxygen. For water applications, please consult Parker with details of water and any additives.



In all diagrams is the peak value of the flow rate in l/min. relating to the maximum permissible flow velocity of 8 m/sec.

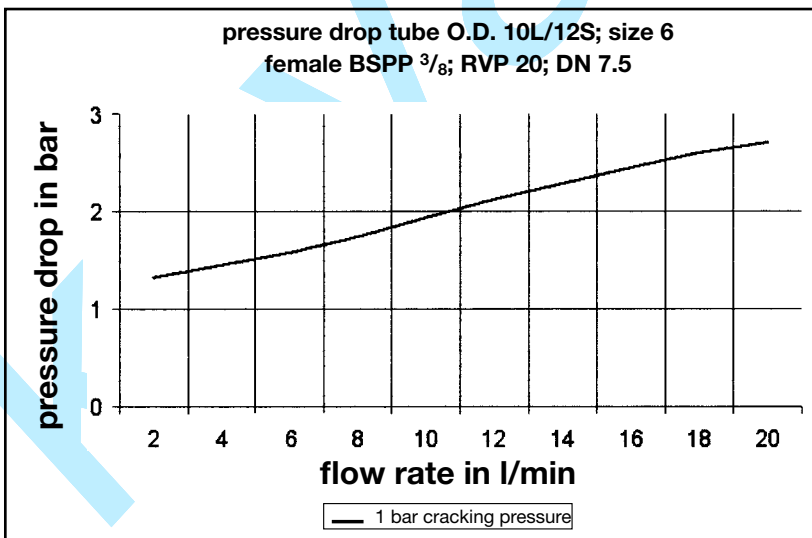
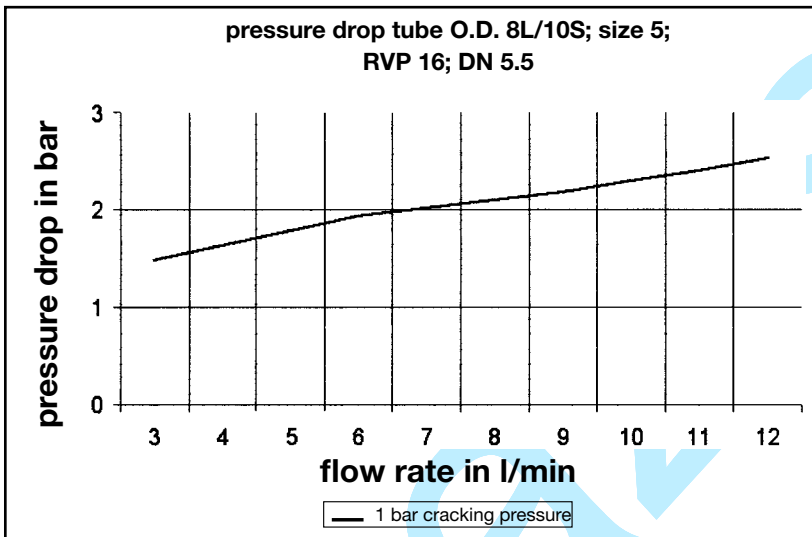
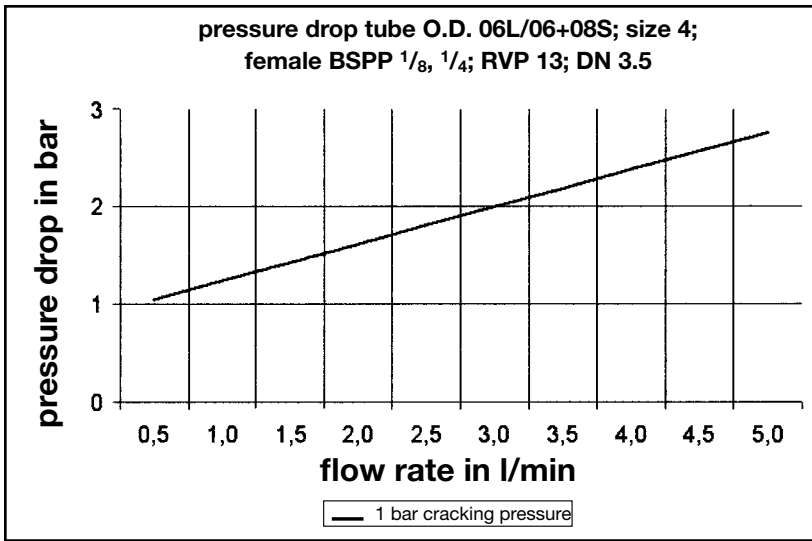

In all diagrams is the peak value of the flow rate in l/min. relating to the maximum permissible flow velocity of 8 m/sec.

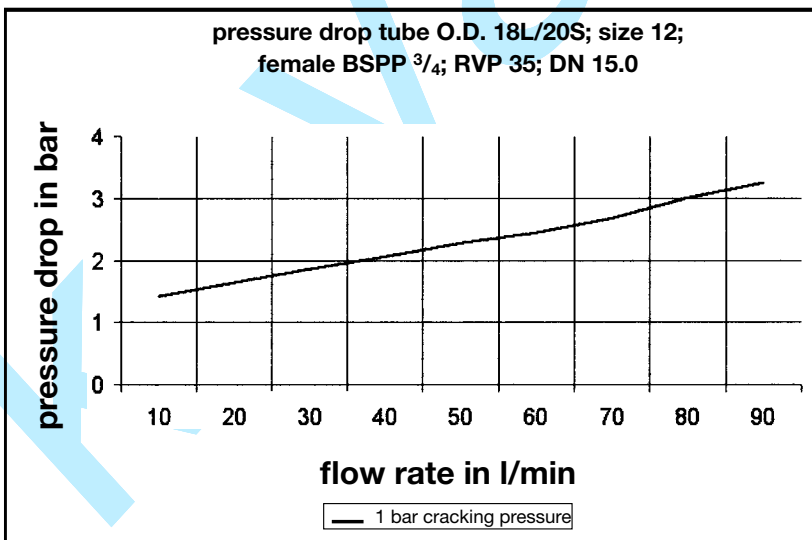
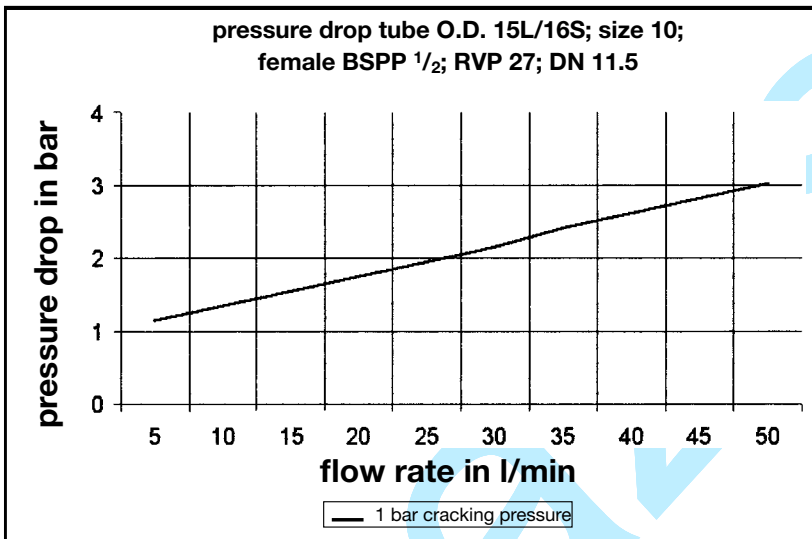
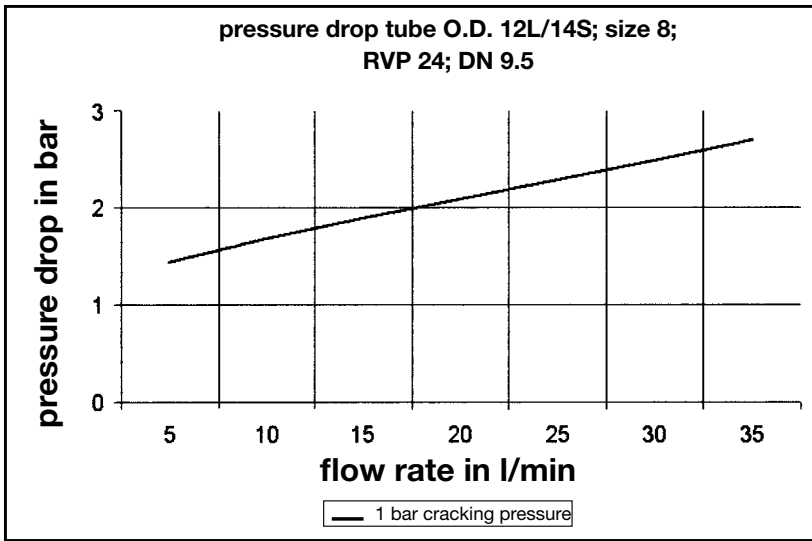

P

In all diagrams is the peak value of the flow rate in l/min. relating to the maximum permissible flow velocity of 8 m/sec.

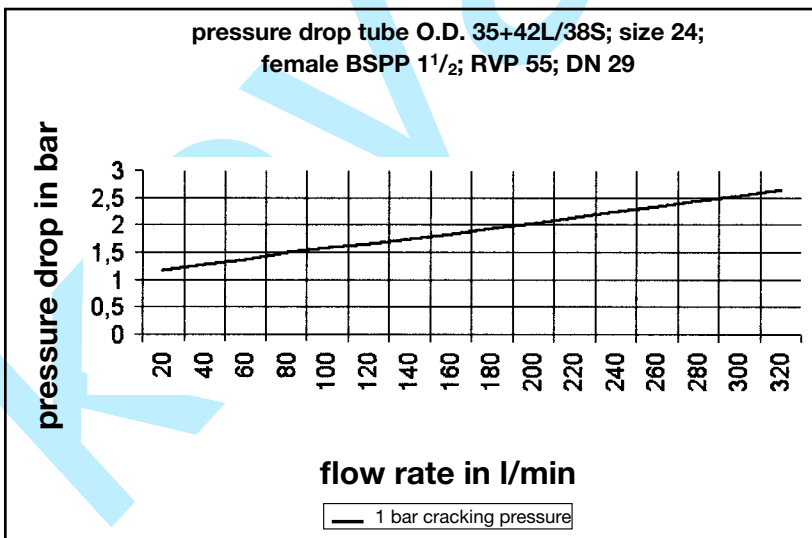
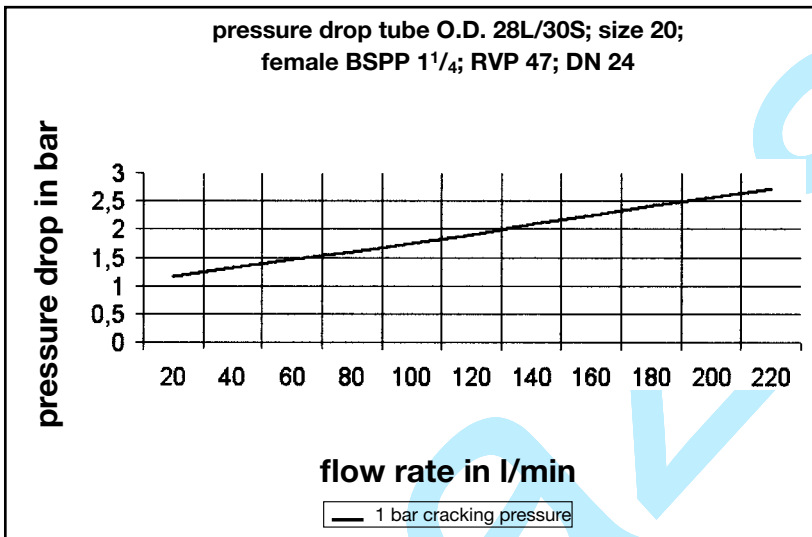
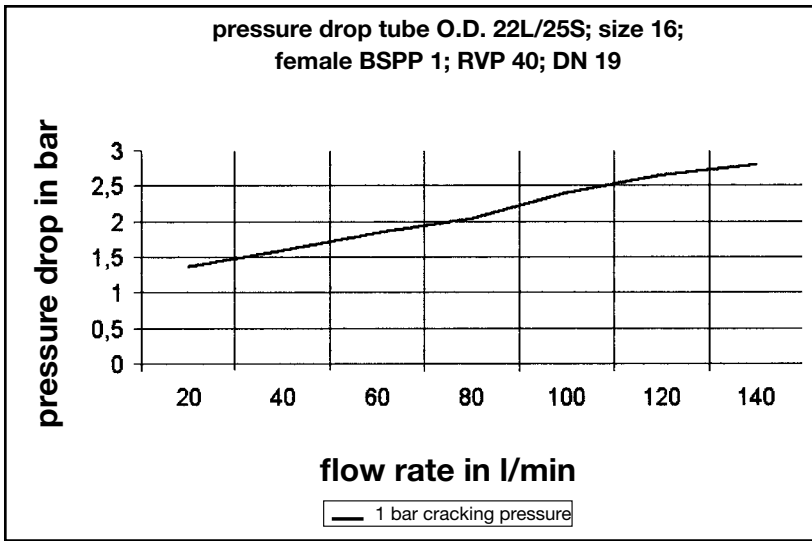

RHD Non return valve

EO 24° cone end / EO 24° cone end

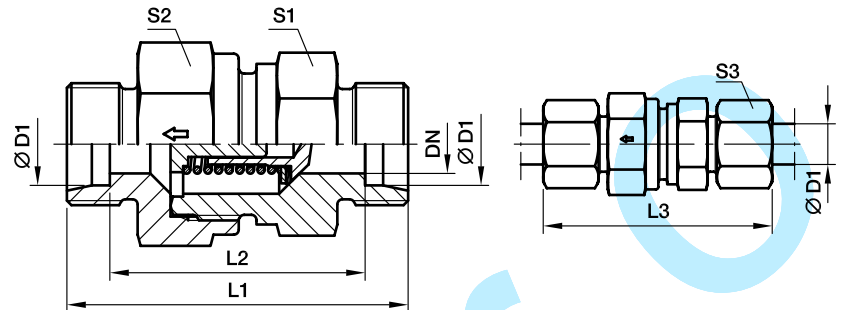

Series	D1 	CF DN	71 DN	CF L1	71 L1	L2	L3	S1	CF S2	71 S2	S3	Weight g/1 piece	Order code*	PN (bar) ¹⁾	
														CF	71
L ³⁾	06	3.5	3.5	43.0	43.0	29.0	58.0	17	17	17	14	46	RHD06LOMD	400	250
	08	5.5	5.5	44.0	44.9	30.0	59.0	19	19	19	17	61	RHD08LOMD	400	250
	10	7.5	7.5	55.0	54.5	40.5	69.5	22	24	24	19	104	RHD10LOMD	400	250
	12	9.5	9.5	58.0	57.5	43.5	72.5	27	30	30	22	166	RHD12LOMD	400	250
	15	11.0	11.5	62.0	61.5	47.5	77.5	27	32	32	27	192	RHD15LOMD	400	250
	18	14.0	14.0	67.0	66.5	51.5	83.5	36	41	36	32	292	RHD18LOMD	400	160
	22	18.0	18.0	77.0	76.5	61.5	93.5	41	46	46	36	472	RHD22LOMD	250	160
	28	23.0	23.0	85.0	84.5	69.5	102.5	50	55	55	41	746	RHD28LOMD	250	100
	35	29.0	29.0	96.0	95.5	74.5	117.5	60	65	60	50	1062	RHD35LOMD	250	100
	42	29.0	29.0	96.0	96.0	74.0	119.0	65	70	70	60	1518	RHD42LOMD	250	100
S ⁴⁾	06	3.5	3.5	48.5	48.5	34.5	63.5	19	19	19	17	70	RHD06SOMD	420	400
	08	3.5	3.5	48.5	48.5	34.5	63.5	19	19	19	19	74	RHD08SOMD	420	400
	10	5.5	5.5	55.5	55.5	40.5	72.5	22	24	24	22	121	RHD10SOMD	420	400
	12	7.5	7.5	57.5	57.5	42.5	74.5	24	27	27	24	148	RHD12SOMD	420	400
	14	9.5	9.5	64.0	63.5	47.5	82.5	27	32	32	27	218	RHD14SOMD	420	315
	16	11.0	11.5	68.0	67.5	50.5	86.5	32	36	36	30	286	RHD16SOMD	420	315
	20	15.0	15.0	76.0	75.5	54.5	97.5	41	50	46	36	506	RHD20SOMD	420	250
	25	19.0	19.0	83.0	82.5	58.5	106.5	46	55	50	46	639	RHD25SOMD	420	250
	30	24.0	24.0	97.0	96.5	69.5	122.5	60	60	60	50	1157	RHD30SOMD	250	250
	38	29.0	29.0	108.0	107.5	75.5	136.5	65	70	70	60	1650	RHD38SOMD	250	250

¹⁾ Pressure shown = item deliverable

³⁾ L = light series; ⁴⁾ S = heavy series

$$\frac{\text{PN (bar)}}{10} = \text{PN (MPa)}$$

Delivery without nut and ring. Information on ordering complete fittings or alternative sealing materials see page I7.

Order code suffixes			
Material	Suffix surface and material	Example	Standard sealing material (no additional suffix needed)
Steel, zinc plated, Cr(VI)-free	CF	RHD06LOMDCF	NBR
Stainless steel	71	RHD06LOMD71	VIT

*Please add the suffixes below according to the material/surface required.

RHV-R-ED Non return valve

EO 24° cone end / Male BSPP thread – ED-seal (ISO 1179)

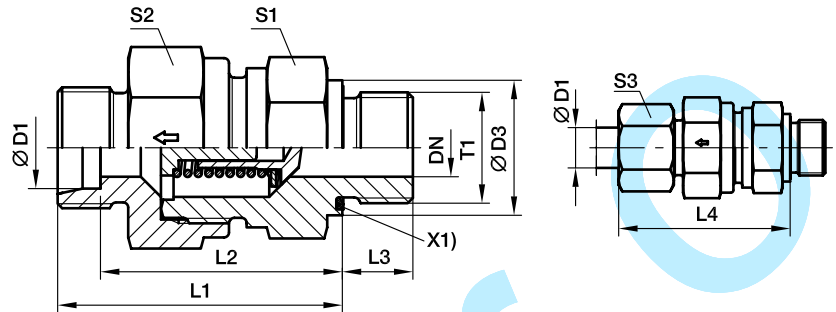

X1) Eolastic sealing

Series	D1	T1	CF DN	71 DN	D3	CF L1	71 L1	L2	L3	L4	S1	CF S2	71 S2	S3	Weight g/1 piece	Order code*	PN (bar) ¹⁾	
																	CF	71
L ³⁾	06	G 1/8 A	3.5	3.5	14	35.0	35.0	28.0	8	42.5	17	17	17	14	47	RHV06LREDOMD	400	250
	08	G 1/4 A	5.5	5.5	19	37.0	37.0	30.0	12	44.5	19	19	19	17	62	RHV08LREDOMD	400	250
	10	G 1/4 A	7.5	7.5	19	46.0	45.5	38.5	12	53.0	22	24	24	19	105	RHV10LREDOMD	400	250
	12	G 3/8 A	9.5	9.5	22	50.0	49.5	42.5	12	57.0	27	30	30	22	175	RHV12LREDOMD	400	250
	15	G 1/2 A	11.0	11.5	27	53.0	52.5	45.5	14	60.5	27	32	32	27	205	RHV15LREDOMD	400	250
	18	G 1/2 A	14.0	14.0	27	58.0	57.5	50.0	14	66.0	36	41	36	32	294	RHV18LREDOMD	400	160
	22	G 3/4 A	18.0	18.0	32	63.0	62.5	55.0	16	71.0	41	46	46	36	450	RHV22LREDOMD	250	160
	28	G 1 A	23.0	23.0	40	71.0	70.5	63.0	18	79.5	50	55	55	41	720	RHV28LREDOMD	250	100
	35	G 1 1/4 A	29.0	29.0	50	80.0	79.5	69.0	20	90.5	60	65	60	50	1050	RHV35LREDOMD	250	100
	42	G 1 1/2 A	29.0	29.0	55	80.0	79.5	68.5	22	91.0	65	70	70	60	1560	RHV42LREDOMD	250	100
S ⁴⁾	06	G 1/4 A	3.5	3.5	19	38.5	38.5	31.5	12	46.0	19	19	19	17	73	RHV06SREDOMD	420	400
	08	G 1/4 A	3.5	3.5	19	38.5	38.5	31.5	12	46.0	19	19	19	19	79	RHV08SREDOMD	420	400
	10	G 3/8 A	5.5	5.5	22	45.5	45.5	38.0	12	54.0	22	24	24	22	132	RHV10SREDOMD	420	400
	12	G 3/8 A	7.5	7.5	22	48.5	48.5	41.0	12	57.0	24	27	27	24	153	RHV12SREDOMD	420	400
	14	G 1/2 A	9.5	9.5	27	53.0	52.5	44.5	14	62.0	27	32	32	27	230	RHV14SREDOMD	420	315
	16	G 1/2 A	11.0	11.5	27	57.0	56.5	48.0	14	66.0	32	36	36	30	293	RHV16SREDOMD	420	315
	20	G 3/4 A	15.0	15.0	32	63.0	62.5	52.0	16	73.5	41	50	46	36	511	RHV20SREDOMD	420	250
	25	G 1 A	19.0	19.0	40	67.0	66.5	54.5	18	78.5	46	55	50	46	648	RHV25SREDOMD	420	250
	30	G 1 1/4 A	24.0	24.0	50	78.0	77.5	64.0	20	90.5	60	60	60	50	1176	RHV30SREDOMD	250	250
	38	G 1 1/2 A	29.0	29.0	55	86.0	85.5	69.5	22	100.0	65	70	70	60	1624	RHV38SREDOMD	250	250

¹⁾ Pressure shown = item deliverable

³⁾ L = light series; ⁴⁾ S = heavy series

$$\frac{PN \text{ (bar)}}{10} = PN \text{ (MPa)}$$

Delivery without nut and ring. Information on ordering complete fittings or alternative sealing materials see page I7.

*Please add the suffixes below according to the material/surface required.

Order code suffixes			
Material	Suffix surface and material	Example	Standard sealing material (no additional suffix needed)
Steel, zinc plated, Cr(VI)-free	CF	RHV06LREDOMDCF	NBR
Stainless steel	71	RHV06LREDOMD71	VIT

RHZ-R-ED Non return valve

Male BSPP thread – ED-seal (ISO 1179) / EO 24° cone end

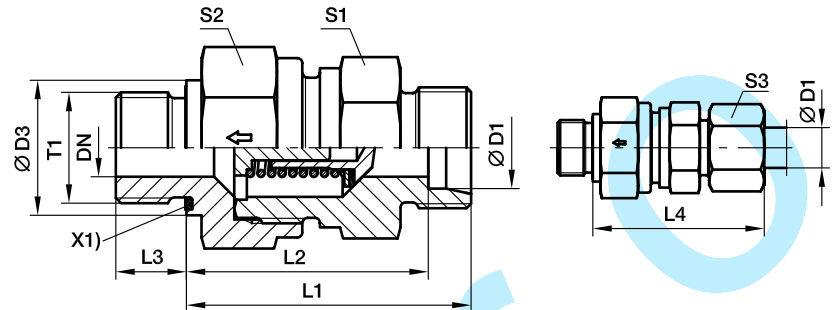

X1) Eolastic sealing

Series	D1	T1	CF DN	71 DN	D3	CF L1	71 L1	L2	L3	L4	S1	CF S2	71 S2	S3	Weight g/1 piece	Order code*	PN (bar) ¹⁾	
																	CF	71
L ³⁾	06	G 1/8 A	3.5	3.5	14	33.5	–	26.5	8	41.0	17	17	17	14	44	RHZ06LREDOMD	400	250
	08	G 1/4 A	5.5	5.5	19	35.5	–	28.5	12	43.0	19	19	19	17	59	RHZ08LREDOMD	400	250
	10	G 1/4 A	7.5	7.5	19	46.0	–	38.5	12	53.0	22	24	24	19	125	RHZ10LREDOMD	400	250
	12	G 3/8 A	9.5	9.5	22	48.0	–	40.5	12	55.0	27	30	30	22	161	RHZ12LREDOMD	400	250
	15	G 1/2 A	11.0	11.5	27	50.0	–	42.5	14	57.5	27	32	32	27	186	RHZ15LREDOMD	400	250
	18	G 1/2 A	14.0	14.0	27	56.0	–	48.0	14	64.0	36	41	36	32	275	RHZ18LREDOMD	400	160
	22	G 3/4 A	18.0	18.0	32	64.0	–	56.0	16	72.0	41	46	46	36	463	RHZ22LREDOMD	250	160
	28	G 1 A	23.0	23.0	40	72.0	–	64.0	18	80.5	50	55	55	41	721	RHZ28LREDOMD	250	100
	35	G 1 1/4 A	29.0	29.0	50	81.0	–	70.0	20	91.5	60	65	60	50	1073	RHZ35LREDOMD	250	100
	42	G 1 1/2 A	29.0	29.0	55	82.0	–	70.5	22	93.0	65	70	70	60	1602	RHZ42LREDOMD	250	100
S ⁴⁾	06	G 1/4 A	3.5	3.5	19	38.5	–	31.5	12	46.0	19	19	19	17	71	RHZ06SREDOMD	420	400
	08	G 1/4 A	3.5	3.5	19	38.5	–	31.5	12	46.0	19	19	19	19	74	RHZ08SREDOMD	420	400
	10	G 3/8 A	5.5	5.5	22	45.5	–	38.0	12	54.0	22	24	24	22	128	RHZ10SREDOMD	420	400
	12	G 3/8 A	7.5	7.5	22	48.5	–	41.0	12	57.0	24	27	27	24	152	RHZ12SREDOMD	420	400
	14	G 1/2 A	9.5	9.5	27	52.0	–	43.5	14	61.0	27	32	32	27	223	RHZ14SREDOMD	420	315
	16	G 1/2 A	11.0	11.5	27	55.0	–	46.0	14	64.0	32	36	36	30	275	RHZ16SREDOMD	420	315
	20	G 3/4 A	15.0	15.0	32	61.0	–	50.0	16	71.5	41	50	46	36	490	RHZ20SREDOMD	420	250
	25	G 1 A	19.0	19.0	40	67.0	–	54.5	18	78.5	50	55	50	46	647	RHZ25SREDOMD	420	250
	30	G 1 1/4 A	24.0	24.0	50	78.0	–	64.0	20	90.5	55	60	60	50	1180	RHZ30SREDOMD	250	250
	38	G 1 1/2 A	29.0	29.0	55	88.0	–	71.5	22	102.0	65	70	70	60	1670	RHZ38SREDOMD	250	250

¹⁾ Pressure shown = item deliverable

³⁾ L = light series; ⁴⁾ S = heavy series

$$\frac{\text{PN (bar)}}{10} = \text{PN (MPa)}$$

Delivery without nut and ring. Information on ordering complete fittings or alternative sealing materials see page I7.

Order code suffixes			
Material	Suffix surface and material	Example	Standard sealing material (no additional suffix needed)
Steel, zinc plated, Cr(VI)-free	CF	RHZ06LREDOMDCF	NBR
Stainless steel	71	RHZ06LREDOMD71	VIT

*Please add the suffixes below according to the material/surface required.

RHV-M-ED Non return valve

EO 24° cone end / Male metric thread – ED-seal (ISO 9974)

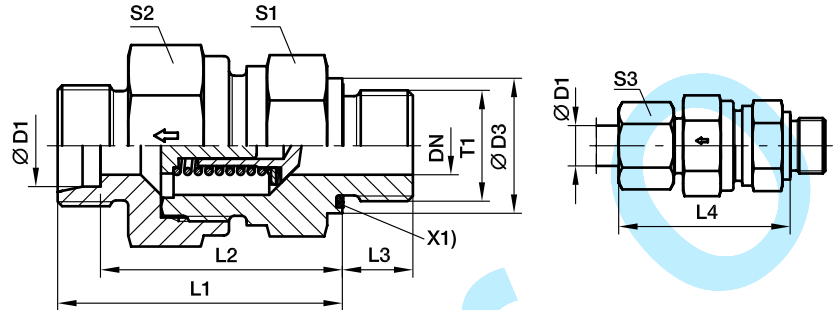

X1) Eolastic sealing

Series	D1	T1	CF DN	71 DN	D3	CF L1	71 L1	L2	L3	L4	S1	CF S2	71 S2	S3	Weight g/1 piece	Order code*	PN (bar) ¹⁾	
																	CF	71
L ³⁾	06	M 10×1.0	3.5	3.5	14	35.0	–	28.0	8	42.5	17	17	17	14	46	RHV06LMEDOMD	400	250
	08	M 12×1.5	5.5	5.5	17	36.0	–	29.0	12	43.5	19	19	19	17	58	RHV08LMEDOMD	400	250
	10	M 14×1.5	7.5	7.5	19	45.5	–	38.5	12	53.0	22	24	34	19	108	RHV10LMEDOMD	400	250
	12	M 16×1.5	9.5	9.5	22	49.5	–	42.5	12	57.0	27	30	30	22	173	RHV12LMEDOMD	400	250
	15	M 18×1.5	11.0	11.5	24	52.5	–	45.5	12	60.5	27	32	32	27	192	RHV15LMEDOMD	400	250
	18	M 22×1.5	14.0	14.0	27	56.0	–	50.0	14	66.0	36	41	36	32	298	RHV18LMEDOMD	400	160
	22	M 26×1.5	18.0	18.0	32	64.0	–	55.0	16	71.0	41	46	46	36	446	RHV22LMEDOMD	250	160
	28	M 33×2.0	23.0	23.0	40	72.0	–	63.0	18	79.5	50	55	55	41	722	RHV28LMEDOMD	250	100
	35	M 42×2.0	29.0	29.0	50	81.0	–	69.0	20	90.5	60	65	60	50	1053	RHV35LMEDOMD	250	100
	42	M 48×2.0	29.0	29.0	55	82.0	–	68.5	22	91.0	65	70	70	60	1563	RHV42LMEDOMD	250	100
S ⁴⁾	06	M 12×1.5	3.5	3.5	17	38.5	–	31.5	12	46.0	19	19	19	17	70	RHV06SMEDOMD	420	400
	08	M 14×1.5	3.5	3.5	19	38.5	–	31.5	12	46.0	19	19	19	19	76	RHV08SMEDOMD	420	400
	10	M 16×1.5	5.5	5.5	22	45.5	–	38.0	12	54.0	22	24	24	22	124	RHV10SMEDOMD	420	400
	12	M 18×1.5	7.5	7.5	24	48.5	–	41.0	12	57.0	24	27	27	24	157	RHV12SMEDOMD	420	400
	14	M 20×1.5	9.5	9.5	26	52.5	–	44.5	14	62.0	27	32	32	27	215	RHV14SMEDOMD	420	315
	16	M 22×1.5	11.0	11.5	27	55.0	–	48.0	14	66.0	32	36	36	30	296	RHV16SMEDOMD	420	315
	20	M 27×2.0	15.0	15.0	32	61.0	–	52.0	16	73.5	41	50	46	36	521	RHV20SMEDOMD	420	250
	25	M 33×2.0	19.0	19.0	40	67.0	–	54.5	18	78.5	46	55	50	46	648	RHV25SMEDOMD	420	250
	30	M 42×2.0	24.0	24.0	50	78.0	–	64.0	20	90.5	60	60	60	50	1178	RHV30SMEDOMD	250	250
	38	M 48×2.0	29.0	29.0	55	88.0	–	69.5	22	100.0	65	70	70	60	1627	RHV38SMEDOMD	250	250

¹⁾ Pressure shown = item deliverable

³⁾ L = light series; ⁴⁾ S = heavy series

$$\frac{PN \text{ (bar)}}{10} = PN \text{ (MPa)}$$

Delivery without nut and ring. Information on ordering complete fittings or alternative sealing materials see page I7.

*Please add the suffixes below according to the material/surface required.

Order code suffixes			
Material	Suffix surface and material	Example	Standard sealing material (no additional suffix needed)
Steel, zinc plated, Cr(VI)-free	CF	RHV06LMEDOMDCF	NBR
Stainless steel	71	RHV06LMEDOMD71	VIT

RHZ-M-ED Non return valve

Male metric thread – ED-seal (ISO 9974) / EO 24° cone end

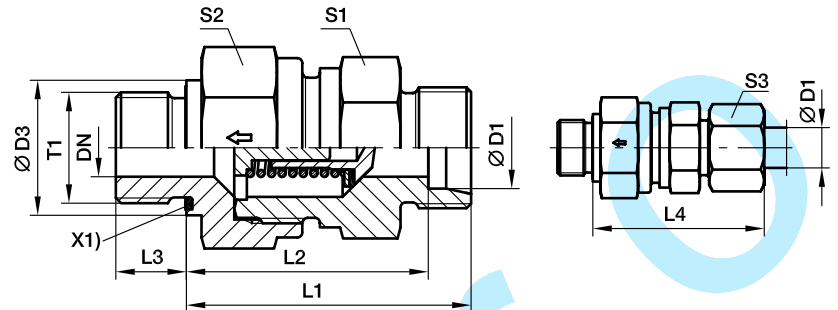

X1) Elastomeric sealing

Series	D1	T1	DN	D3	L1	L2	L3	L4	S1	S2	S3	Weight g/1 piece	Order code*	PN (bar) ¹⁾	
														CF	71
L ³⁾	06	M 10×1.0	3.5	14	33.5	26.5	8	41.0	17	17	14	44	RHZ06LMEDOMD	400	250
	08	M 12×1.5	5.5	17	35.5	28.5	12	43.0	19	19	17	58	RHZ08LMEDOMD	400	250
	10	M 14×1.5	7.5	19	45.5	38.5	12	53.0	22	24	19	104	RHZ10LMEDOMD	400	250
	12	M 16×1.5	9.5	22	47.5	40.5	12	55.0	27	30	22	169	RHZ12LMEDOMD	400	250
	15	M 18×1.5	11.5	24	49.5	42.5	12	57.5	27	32	27	174	RHZ15LMEDOMD	400	250
	18	M 22×1.5	14.0	27	55.5	48.0	14	64.0	36	41	32	279	RHZ18LMEDOMD	400	160
	22	M 26×1.5	18.0	32	63.5	56.0	16	72.0	41	46	36	459	RHZ22LMEDOMD	250	160
	28	M 33×2.0	23.0	40	71.5	64.0	18	80.5	50	55	41	721	RHZ28LMEDOMD	250	100
	35	M 42×2.0	29.0	50	80.5	70.0	20	91.5	60	65	50	1078	RHZ35LMEDOMD	250	100
	42	M 48×2.0	29.0	55	81.5	70.5	22	93.0	65	70	60	1601	RHZ42LMEDOMD	250	100
S ⁴⁾	06	M 12×1.5	3.5	17	38.5	31.5	12	46.0	19	19	17	70	RHZ06SMEDOMD	420	400
	08	M 14×1.5	3.5	19	38.5	31.5	12	46.0	19	19	19	75	RHZ08SMEDOMD	420	400
	10	M 16×1.5	5.5	22	45.5	38.0	12	54.0	22	24	22	123	RHZ10SMEDOMD	420	400
	12	M 18×1.5	7.5	24	48.5	41.0	12	57.0	24	27	24	157	RHZ12SMEDOMD	420	400
	14	M 20×1.5	9.5	26	51.5	43.5	14	61.0	27	32	27	214	RHZ14SMEDOMD	420	315
	16	M 22×1.5	11.5	27	54.5	46.0	14	64.0	32	36	30	279	RHZ16SMEDOMD	420	315
	20	M 27×2.0	15.0	32	60.5	50.0	16	71.5	41	50	36	487	RHZ20SMEDOMD	420	250
	25	M 33×2.0	19.0	40	68.0	54.5	18	78.5	46	55	46	647	RHZ25SMEDOMD	420	250
	30	M 42×2.0	24.0	50	77.5	64.0	20	90.5	60	60	50	1180	RHZ30SMEDOMD	250	250
	38	M 48×2.0	29.0	55	87.5	71.5	22	102.0	65	70	60	1669	RHZ38SMEDOMD	250	250

¹⁾ Pressure shown = item deliverable

³⁾ L = light series; ⁴⁾ S = heavy series

$$\frac{\text{PN (bar)}}{10} = \text{PN (MPa)}$$

Delivery without nut and ring. Information on ordering complete fittings or alternative sealing materials see page I7.

*Please add the **suffixes** below according to the material/surface required.

Order code suffixes			
Material	Suffix surface and material	Example	Standard sealing material (no additional suffix needed)
Steel, zinc plated, Cr(VI)-free	CF	RHZ06LMEDOMDCF	NBR
Stainless steel	71	RHZ06LMEDOMD71	VIT

RHDI Non return valve

Female BSPP thread (ISO 1179-1) / Female BSPP thread (ISO 1179-1)

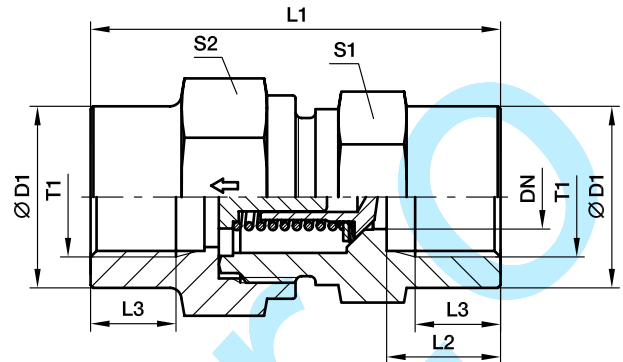

Series	T1	DN	D1	L1	L2	L3	S1	S2	Weight g/1 piece	Order code*	PN (bar) ¹⁾	
											CF	71
L ³⁾	G 1/8	3.5	19	42.5	12.0	8.0	19	19	76	RHDI1/8	400	400
	G 1/4	3.5	19	51.0	16.0	12.0	19	19	82	RHDI1/4	400	400
	G 3/8	7.5	24	60.0	17.0	12.0	24	27	157	RHDI3/8	400	400
	G 1/2	11.5	32	72.0	20.0	15.0	32	36	344	RHDI1/2	315	315
	G 3/4	15.0	41	84.0	22.0	16.5	41	46	664	RHDI3/4	250	250
	G 1	19.0	46	95.0	25.5	19.0	46	50	821	RHDI1	250	250
G 1 1/4	24.0	60	110.0	28.0	21.5	60	60	1581	RHDI11/4	250	250	
G 1 1/2	29.0	65	114.0	28.5	22.0	65	70	1919	RHDI11/2	250	250	

¹⁾Pressure shown = item deliverable

³⁾L = light series

$$\frac{PN \text{ (bar)}}{10} = PN \text{ (MPa)}$$

Delivery without nut and ring. Information on ordering complete fittings or alternative sealing materials see page 17.

Order code suffixes			
Material	Suffix surface and material	Example	Standard sealing material (no additional suffix needed)
Steel, zinc plated, Cr(VI)-free	CF	RHDI1/8CF	NBR
Stainless steel	71	RHDI1/871	VIT

*Please add the **suffixes** below according to the material/surface required.

RVP Non return valve cartridge

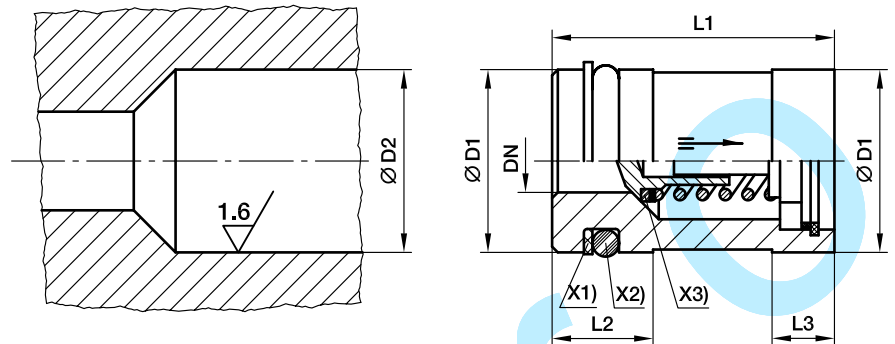

- X1) Supporting ring PTFE
- X2) O-ring NBR
- X3) Sealing disc NBR

Valve ITL	DN	D1	D2	L1 ± 0,15	L2	L3	O-ring	Supporting ring	Weight g/1 piece	Order code*	PN (bar) ¹⁾	
											CF	71
6-L/6 & 8-S	3.5	12.945 ± 0.055	13 ^{+0.12 +0.05}	23.15	9.5	6.0	8.3×2.4	SRA 13-2.05-1.0	21	RVP13	420	400
8-L/10-S	5.5	15.945 ± 0.055	16 ^{+0.12 +0.05}	26.65	9.5	6.5	11.3×2.4	SRA 16-2.05-1.0	32	RVP16	420	400
10-L/12-S	7.5	19.935 ± 0.065	20 ^{+0.142 +0.065}	30.15	9.5	6.5	15.3×2.4	SRA 20-2.05-1.0	54	RVP20	420	400
12-L/14-S	9.5	23.935 ± 0.065	24 ^{+0.149 +0.065}	35.15	12.0	7.5	18.2×3	SRA 24-2.6-1.0	80	RVP24	420	315
15-L/16-S	11.5	26.935 ± 0.065	27 ^{+0.149 +0.065}	38.15	12.0	7.5	21.2×3	SRA 27-2.6-1.0	105	RVP27	420	315
18-L/20-S	15.0	34.92 ± 0.08	35 ^{+0.18 +0.08}	44.65	12.0	9.5	29.2×3	SRA 35-2.5-1.0	204	RVP35	420	250
22-L/25-S	19.0	39.92 ± 0.08	40 ^{+0.18 +0.08}	50.65	12.0	11.0	34.2×3	SRA 40-2.5-1.0	275	RVP40	420	250
28-L/30-S	24.0	46.92 ± 0.08	47 ^{+0.18 +0.08}	60.15	13.0	13.0	41.0×3	SRA 47-2.6-1.5	412	RVP47	250	250
35-L/38-S	29.0	54.905 ± 0.095	55 ^{+0.22 +0.01}	70.15	16.0	13.0	44.2×5.7	SRA 55-5.1-1.5	607	RVP55	250	250

¹⁾ Pressure shown = item deliverable

$$\frac{PN \text{ (bar)}}{10} = PN \text{ (MPa)}$$

Delivery without nut and ring. Information on ordering complete fittings or alternative sealing materials see page 17.

*Please add the **suffixes** below according to the material/surface required.

Order code suffixes			
Material	Suffix surface and material	Example	Standard sealing material (no additional suffix needed)
Steel, zinc plated, Cr(VI)-free	CF	RVP13CF	NBR
Stainless steel	71	RVP1371	VIT

I-TL Internal parts of non return valve

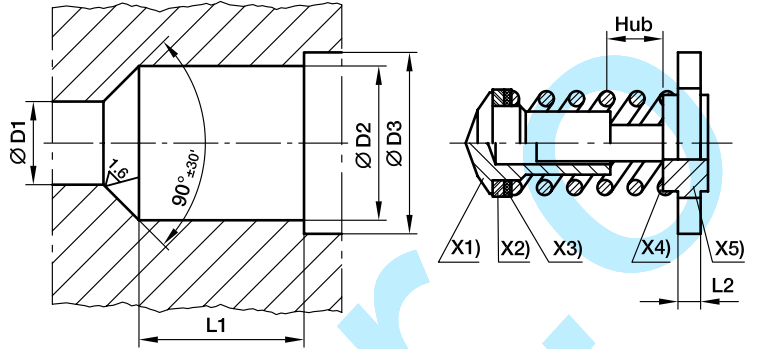

- X1) poppet
- X2) sealing disc (smooth side to the poppet)
- X3) cover disc
- X4) spring
- X5) passage disc

Series	Tube O.D.	D1 ^{+0.1}	D2 ^{+0.1}	D3 ^{+0.1}	L1 ^{±0.1}	L2	Hub	Weight g/1 piece	Order code*	PN (bar) ¹⁾	
										CF	71
L/S/S	06/06/08	3.5	7.5	8.6	8.2	2.0	1.0	2	ITL06L/06+08S	*	*
L/S	08/10	5.5	10.2	11.6	11.0	2.0	1.7	4	ITL08L/10S	*	*
L/S	10/12	7.5	13.0	14.1	14.0	2.0	2.3	7	ITL10L/12S	*	*
L/S	12/14	9.5	16.7	18.1	16.5	2.5	2.9	13	ITL12L/14S	*	*
L/S	15/16	11.5	19.5	20.6	19.0	2.5	3.5	18	ITL15L/16S	*	*
L/S	18/20	15.0	25.2	27.1	22.5	3.0	4.4	37	ITL18L/20S	*	*
L/S	22/25	19.0	30.8	32.6	27.0	3.0	5.5	54	ITL22L/25S	*	*
L/S	28/30	24.0	38.6	40.6	32.5	3.5	7.3	107	ITL28L/30S	*	*
L/L/S	35/38/42	29.0	45.7	48.1	37.5	3.5	8.9	144	ITL35L+42I/38S	*	*

* = item deliverable

Delivery without nut and ring. Information on ordering complete fittings or alternative sealing materials see page 17.

*Please add the suffixes below according to the material/surface required.

Order code suffixes			
Material	Suffix surface and material	Example	Standard sealing material (no additional suffix needed)
Steel, zinc plated, Cr(VI)-free	CF	ITL06L/06+008S	NBR
Stainless steel	71	ITL06L71/06+008S	VIT

RHD/V/Z Non return valves with O-Lok® or Triple-Lok® connections

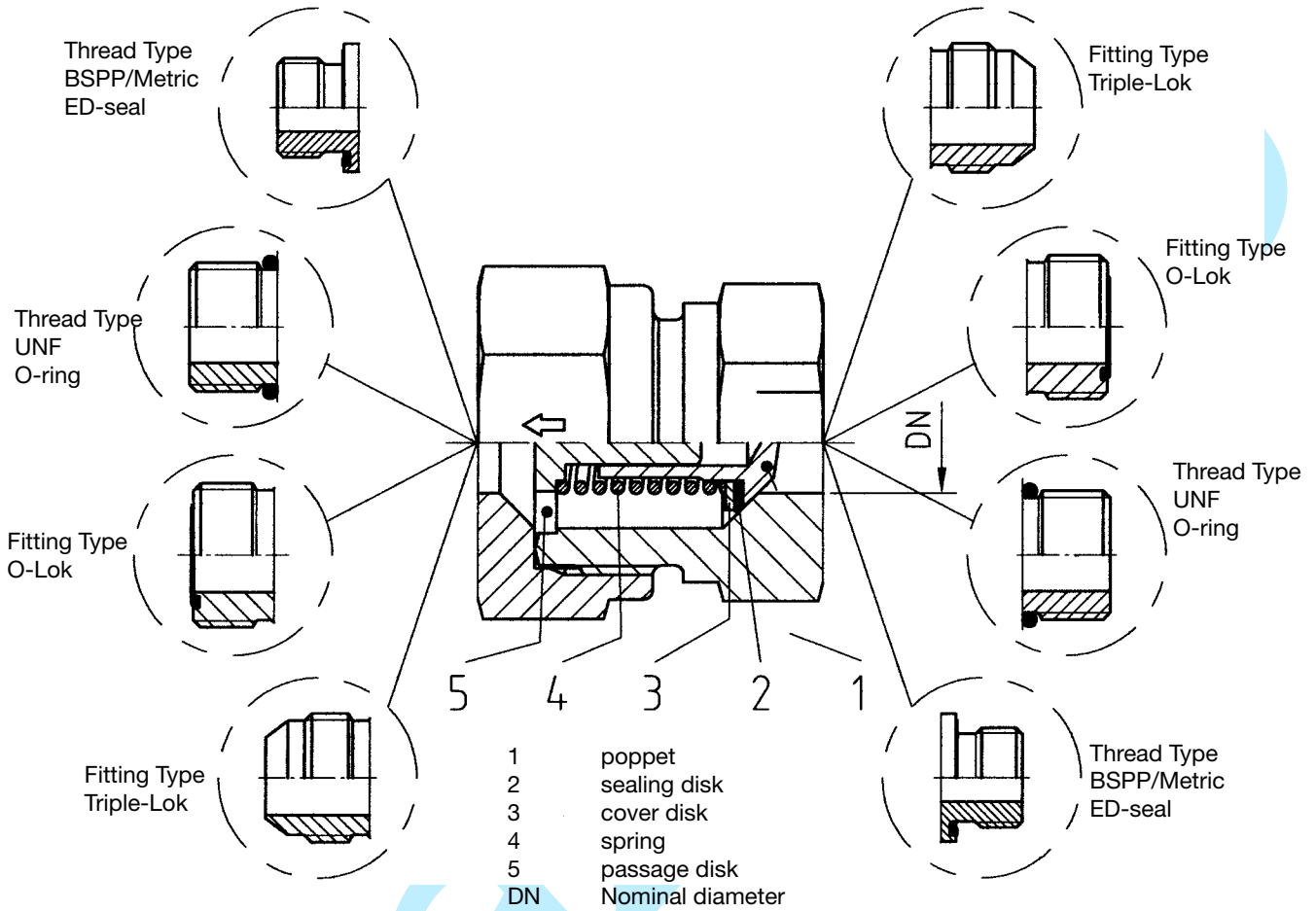

Material:

- Steel zinc-plated CF Cr(VI)-free, seals in NBR (e.g. Perbunan)
- Internal parts in stainless steel with FKM also available on request.

Perbunan = registered trademark of Bayer



RHDMLOS Non return valve

O-Lok® ORFS end / O-Lok® ORFS end

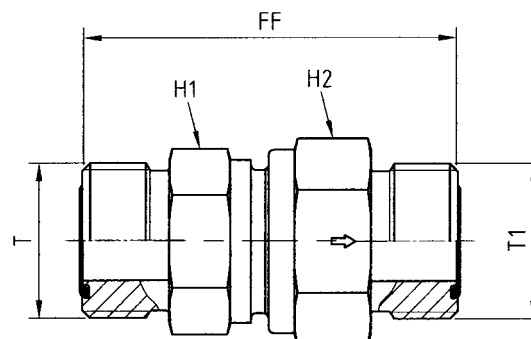

Tube 1 O.D.		Tube 2 O.D.		ORFS (UN/UNF) thread T	ORFS (UN/UNF) thread T1	H1	H2	FF	DN (Nom. diam.)	Weight g/1 piece	Order code*	PN (bar) ¹⁾
mm	Inch	mm	Inch								CF	
6	1/4	6	1/4	9/16-18 UNF	9/16-18 UNF	19	19	44.5	3.5	108	4RHDMLOS	420
8, 10	5/16, 3/8	8, 10	5/16, 3/8	11/16-16 UNF	11/16-16 UNF	22	24	53.5	5.5	188	6RHDMLOS	420
12	1/2	12	1/2	13/16-16 UNF	13/16-16 UNF	24	27	59.5	7.5	223	8RHDMLOS	420
14, 15, 16	5/8	14, 15, 16	5/8	1-14 UNF	1-14 UNF	32	36	70.5	11.5	428	10RHDMLOS	420
18, 20	3/4	18, 20	3/4	1 3/16-12 UNF	1 3/16-12 UNF	41	46	77.5	15.0	731	12RHDMLOS	420
22, 25	1	22, 25	1	1 7/16-12 UNF	1 7/16-12 UNF	46	50	81.5	19.0	1076	16RHDMLOS	420
28, 30, 32	1 1/4	28, 30, 32	1 1/4	1 11/16-12 UNF	1 11/16-12 UNF	60	60	91.5	24.0	1630	20RHDMLOS	250
35, 38	1 1/2	35, 38	1 1/2	2-12 UNF	2-12 UNF	65	70	98.5	29.0	2362	24RHDMLOS	250

¹⁾Pressure shown = item deliverable

$\frac{\text{PN (bar)}}{10} = \text{PN (MPa)}$

Information on ordering complete fittings or alternative sealing materials see page 17.

*Please add the **suffixes** below according to the material/surface required.

Order code suffixes			
Material	Suffix surface and material	Example	Standard sealing material (no additional suffix needed)
Steel, zinc plated, Cr(VI)-free	CF	4RHDMLOSCF	NBR

RHV42EDMLOS Non return valve

Male BSPP thread – ED-seal (ISO 1179) / O-Lok® ORFS end

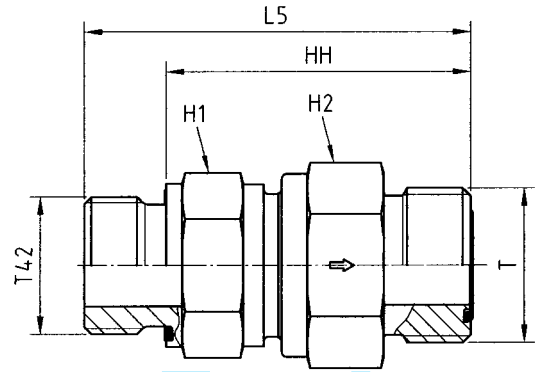

Tube O.D.		BSPP thread	ORFS (UN/UNF)					DN (Nom. diam.)	Weight g/1 piece	Order code*	PN (bar) ¹⁾
mm	Inch	T42	T	H1	H2	L5	HH				CF
6	1/4	G 1/8	9/16-18 UNF	19	19	44.5	36.5	3.5	92	4RHV42EDMLOS	420
8, 10	5/16, 3/8	G 1/4	11/16-16 UNF	24	27	56.5	44.5	6.5	165	6RHV42EDMLOS	420
12	1/2	G 3/8	13/16-16 UNF	24	27	61.5	49.5	7.5	191	8RHV42EDMLOS	420
14, 15, 16	5/8	G 1/2	1-14 UNF	32	36	70.0	56.0	11.5	366	10RHV42EDMLOS	420
18, 20	3/4	G 3/4	1 3/16-12 UNF	41	46	77.5	63.5	15.0	631	12RHV42EDMLOS	420
22, 25	1	G 1	1 7/16-12 UNF	46	50	84.0	66.0	19.0	863	16RHV42EDMLOS	420
28, 30, 32	1 1/4	G 1 1/4	1 11/16-12 UNF	60	60	95.0	75.0	24.0	1403	20RHV42EDMLOS	250
35, 38	1 1/2	G 1 1/2	2-12 UNF	65	70	105.0	83.0	29.0	1969	24RHV42EDMLOS	250

¹⁾Pressure shown = item deliverable

$$\frac{\text{PN (bar)}}{10} = \text{PN (MPa)}$$

Information on ordering complete fittings or alternative sealing materials see page 17.

*Please add the **suffixes** below according to the material/surface required.

Order code suffixes			
Material	Suffix surface and material	Example	Standard sealing material (no additional suffix needed)
Steel, zinc plated, Cr(VI)-free	CF	4RHV42EDMLOSCF	NBR

RHZ42EDMLOS Non return valve

O-Lok® ORFS end / Male BSPB thread – ED-seal (ISO 1179)

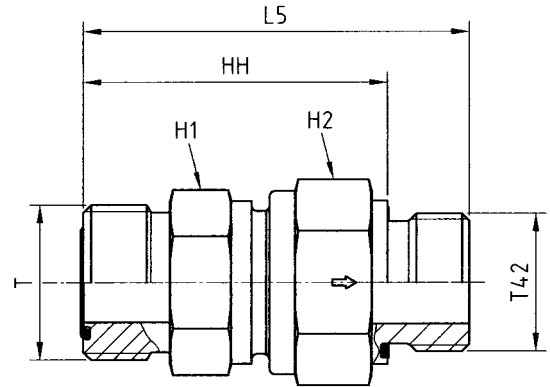

Tube O.D.		BSPB thread	ORFS (UN/UNF) thread T	H1	H2	L5	HH	DN (Nom. diam.)	Weight g/1 piece	Order code*	PN (bar) ¹⁾	CF
6	1/4	G 1/8	9/16-18 UNF	19	19	44.5	36.5	3.5	91	4RHZ42EDMLOS	420	
8, 10	5/16, 3/8	G 1/4	11/16-16 UNF	24	27	56.5	44.5	6.5	161	6RHZ42EDMLOS	420	
12	1/2	G 3/8	13/16-16 UNF	24	27	61.5	49.5	7.5	190	8RHZ42EDMLOS	420	
14, 15, 16	5/8	G 1/2	1-14 UNF	32	36	70.0	56.0	11.5	348	10RHZ42EDMLOS	420	
18, 20	3/4	G 3/4	1 3/16-12 UNF	41	46	77.5	53.5	15.0	634	12RHZ42EDMLOS	420	
22, 25	1	G 1	1 7/16-12 UNF	46	50	84.0	66.0	19.0	863	16RHZ42EDMLOS	420	
28, 30, 32	1 1/4	G 1 1/4	1 11/16-12 UNF	60	60	95.0	75.0	24.0	1397	20RHZ42EDMLOS	250	
35, 38	1 1/2	G 1 1/2	2-12 UNF	65	70	105.0	83.0	29.0	2001	24RHZ42EDMLOS	250	

¹⁾ Pressure shown = item deliverable

$$\frac{\text{PN (bar)}}{10} = \text{PN (MPa)}$$

Information on ordering complete fittings or alternative sealing materials see page 17.

*Please add the **suffixes** below according to the material/surface required.

Order code suffixes			
Material	Suffix surface and material	Example	Standard sealing material (no additional suffix needed)
Steel, zinc plated, Cr(VI)-free	CF	4RHZ42EDMLOSCF	NBR

RHV50MLOS Non return valve

Male UN/UNF thread – O-ring (ISO 11926) / O-Lok® ORFS end

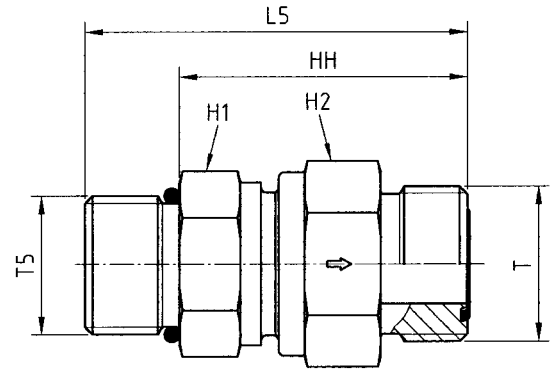

Tube O.D.		UNF male thread T5	ORFS (UN/UNF) thread T	H1	H2	L5	HH	DN (Nom. diam.)	Weight g/1 piece	Order code*	PN (bar) ¹⁾
mm	Inch										CF
6	1/4	7/16-20 UNF	9/16-18 UNF	19	19	45.5	34.5	3.5	92	4RHV50MLOS	420
8, 10	5/16, 3/8	9/16-18 UNF	11/16-16 UNF	22	24	54.5	42.5	5.5	165	6RHV50MLOS	420
12	1/2	3/4-16 UNF	13/16-16 UNF	24	27	60.5	46.5	5.5	165	8RHV50MLOS	420
14, 15, 16	5/8	7/8-14 UNF	1-14 UNF	32	36	71.0	55.0	11.5	366	10RHV50MLOS	420
18, 20	3/4	1 1/16-12 UN	1 3/16-12 UNF	41	46	79.0	60.5	15.0	631	12RHV50MLOS	420
22, 25	1	1 5/16-12 UN	1 7/16-12 UNF	46	50	82.5	64.0	19.0	863	16RHV50MLOS	420
28, 30, 32	1 1/4	1 5/8-12 UN	1 11/16-12 UNF	60	60	92.5	74.0	24.0	1403	20RHV50MLOS	250
35, 38	1 1/2	1 7/8-12 UN	2-12 UNF	65	70	99.5	81.0	29.0	1969	24RHV50MLOS	250

¹⁾ Pressure shown = item deliverable

$$\frac{\text{PN (bar)}}{10} = \text{PN (MPa)}$$

Information on ordering complete fittings or alternative sealing materials see page I7.

*Please add the **suffixes** below according to the material/surface required.

Order code suffixes			
Material	Suffix surface and material	Example	Standard sealing material (no additional suffix needed)
Steel, zinc plated, Cr(VI)-free	CF	RHV50MLOSCF	NBR

RHZ50MLOS Non return valve

O-Lok® ORFS end / Male UN/UNF thread – O-ring (ISO 11926)

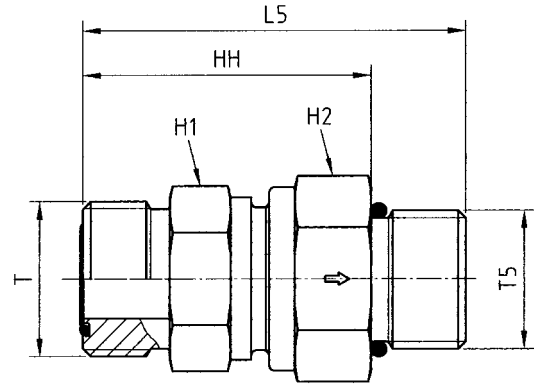

Tube O.D.		UNF male thread T5	ORFS (UN/UNF) thread T	H1	H2	L5	HH	DN (Nom. diam.)	Weight g/1 piece	Order code*	PN (bar) ¹⁾
mm	Inch										CF
6	1/4	7/16-20 UNF	9/16-18 UNF	19	19	45.5	34.5	3.5	91	4RHZ50MLOS	420
8, 10	5/16, 3/8	9/16-18 UNF	11/16-16 UNF	22	24	54.5	42.5	5.5	161	6RHZ50MLOS	420
12	1/2	3/4-16 UNF	13/16-16 UNF	24	27	60.5	46.5	5.5	161	8RHZ50MLOS	420
14, 15, 16	5/8	7/8-14 UNF	1-14 UNF	32	36	71.0	55.0	11.5	348	10RHZ50MLOS	420
18, 20	3/4	1 1/16-12 UN	1 3/16-12 UNF	41	46	79.0	60.5	15.0	634	12RHZ50MLOS	420
22, 25	1	1 5/16-12 UN	1 7/16-12 UNF	46	50	82.5	64.0	19.0	863	16RHZ50MLOS	420
28, 30, 32	1 1/4	1 5/8-12 UN	1 11/16-12 UNF	60	60	92.5	74.0	24.0	1397	20RHZ50MLOS	250
35, 38	1 1/2	1 7/8-12 UN	2-12 UNF	65	70	99.5	81.0	29.0	2001	24RHZ50MLOS	250

¹⁾ Pressure shown = item deliverable

$$\frac{PN \text{ (bar)}}{10} = PN \text{ (MPa)}$$

Information on ordering complete fittings or alternative sealing materials see page I7.

*Please add the **suffixes** below according to the material/surface required.

Order code suffixes			
Material	Suffix surface and material	Example	Standard sealing material (no additional suffix needed)
Steel, zinc plated, Cr(VI)-free	CF	4RHZ50MLOSCF	NBR

RHV82EDMLOS Non return valve

Male metric thread – ED-seal (ISO 9974) / O-Lok® ORFS end

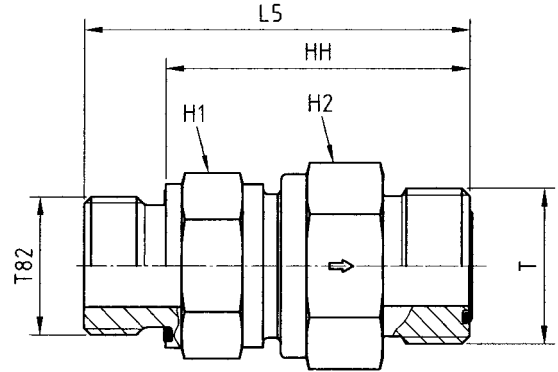

Tube O.D.		metric thread T82	ORFS (UN/UNF) thread T	H1	H2	L5	HH	DN (Nom. diam.)	Weight g/1 piece	Order code*	PN (bar) ¹⁾
mm	Inch										CF
6	1/4	M 12×1.5	9/16-18 UNF	19	19	48.5	36.5	3.5	89	4M12RHV82EDMLOS	420
8, 10	5/16, 3/8	M 16×1.5	11/16-16 UNF	22	24	56.5	44.5	5.5	157	6M16RHV82EDMLOS	420
12	1/2	M 18×1.5	13/16-16 UNF	24	27	61.5	49.5	7.5	195	8M18RHV82EDMLOS	420
14, 15, 16	5/8	M 22×1.5	1-14 UNF	32	36	72.0	58.0	11.5	369	10M22RHV82EDMLOS	420
18, 20	3/4	M 27×2.0	1 3/16-12 UNF	41	46	79.5	63.5	15.0	628	12M27RHV82EDMLOS	420
22, 25	1	M 33×2.0	1 7/16-12 UNF	46	50	84.0	66.0	19.0	867	16M33RHV82EDMLOS	420
28, 30, 32	1 1/4	M 42×2.0	1 11/16-12 UNF	60	60	95.0	75.0	24.0	1409	20M42RHV82EDMLOS	250
35, 38	1 1/2	M 48×2.0	2-12 UNF	65	70	103.0	81.0	29.0	1970	24M48RHV82EDMLOS	250

¹⁾ Pressure shown = item deliverable

$$\frac{\text{PN (bar)}}{10} = \text{PN (MPa)}$$

Information on ordering complete fittings or alternative sealing materials see page I7.

*Please add the **suffixes** below according to the material/surface required.

Order code suffixes			
Material	Suffix surface and material	Example	Standard sealing material (no additional suffix needed)
Steel, zinc plated, Cr(VI)-free	CF	4M12RHV82EDMLOSCF	NBR

RHZ82EDMLOS Non return valve

O-Lok® ORFS end / Male metric thread – ED-seal (ISO 9974)

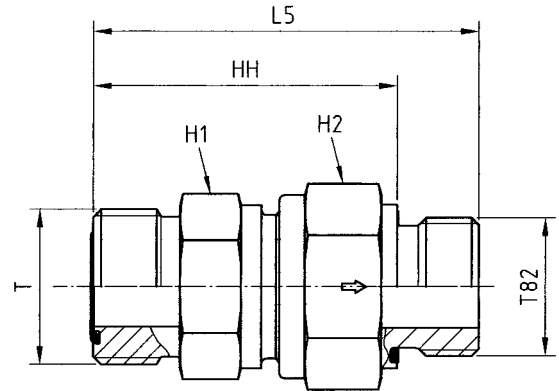

Tube O.D.		metric thread T82	ORFS (UN/UNF) thread T	H1	H2	L5	HH	DN (Nom. diam.)	Weight g/1 piece	Order code*	PN (bar) ¹⁾
mm	Inch										CF
6	1/4	M 12×1.5	9/16-18 UNF	19	19	48.5	36.5	3.5	89	4M12RHZ82EDMLOS	420
8, 10	5/16, 3/8	M 16×1.5	11/16-16 UNF	24	27	59.1	47.1	7.5	156	6M16RHZ82EDMLOS	420
12	1/2	M 18×1.5	13/16-16 UNF	24	27	61.5	49.5	7.5	195	8M18RHZ82EDMLOS	420
14, 15, 16	5/8	M 22×1.5	1-14 UNF	32	36	70.0	56.0	11.5	352	10M22RHZ82EDMLOS	420
18, 20	3/4	M 27×2.0	1 3/16-12 UNF	41	46	77.5	61.5	15.0	608	12M27RHZ82EDMLOS	420
22, 25	1	M 33×2.0	1 7/16-12 UNF	46	50	84.0	66.0	19.0	965	16M33RHZ82EDMLOS	420
28, 30, 32	1 1/4	M 42×2.0	1 11/16-12 UNF	60	60	95.0	75.0	24.0	1396	20M42RHZ82EDMLOS	250
35, 38	1 1/2	M 48×2.0	2-12 UNF	65	70	115.0	93.0	29.0	1978	24M48RHZ82EDMLOS	250

¹⁾ Pressure shown = item deliverable

$$\frac{\text{PN (bar)}}{10} = \text{PN (MPa)}$$

Information on ordering complete fittings or alternative sealing materials see page 17.

*Please add the **suffixes** below according to the material/surface required.

Order code suffixes			
Material	Suffix surface and material	Example	Standard sealing material (no additional suffix needed)
Steel, zinc plated, Cr(VI)-free	CF	4M12RHZ82EDMLOSCF	NBR

RHDMTXS Non return valve

Triple-Lok® 37° flare end / Triple-Lok® 37° flare end

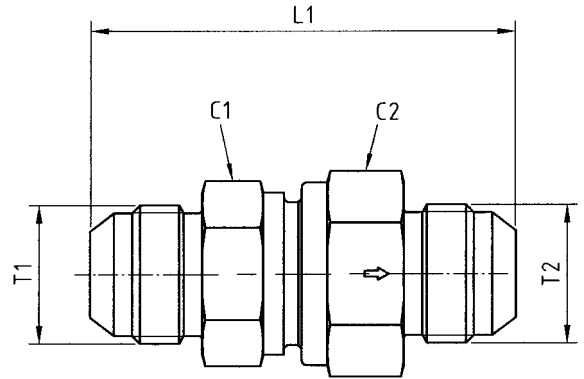

Tube 1 O.D.		Tube 2 O.D.		Thread JIC SAE T1	Thread JIC SAE T2	C1	C2	L1	DN (Nom. diam.)	Weight g/1 piece	Order code*	PN (bar) ¹⁾
mm	Inch	mm	Inch									CF
6	1/4	6	1/4	7/16-20 UNF	7/16-20 UNF	19	19	52.5	3.5	108	4RHDMTXS	420
8	5/16	8	5/16	1/2-20 UNF	1/2-20 UNF	22	24	59.5	5.5	188	5RHDMTXS	420
10	3/8	10	3/8	9/16-18 UNF	9/16-18 UNF	24	27	61.5	7.5	223	6RHDMTXS	420
12	1/2	12	1/2	3/4-16 UNF	3/4-16 UNF	27	32	69.5	9.5	324	8RHDMTXS	420
14, 15, 16	5/8	14, 15, 16	5/8	7/8-14 UNF	7/8-14 UNF	32	36	78.5	11.5	428	10RHDMTXS	350
18, 20	3/4	18, 20	3/4	1 1/16-12 UN	1 1/16-12 UN	41	46	87.5	15.0	731	12RHDMTXS	350
25	1	25	1	1 5/16-12 UN	1 5/16-12 UN	46	50	92.5	19.0	1076	16RHDMTXS	280
28, 30, 32	1 1/4	28, 30, 32	1 1/4	1 5/8-12 UN	1 5/8-12 UN	60	60	105.5	24.0	1630	20RHDMTXS	250
35, 38	1 1/2	35, 38	1 1/2	1 7/8-12 UN	1 7/8-12 UN	65	70	118.5	29.0	2362	24RHDMTXS	210

¹⁾Pressure shown = item deliverable

$$\frac{\text{PN (bar)}}{10} = \text{PN (MPa)}$$

Information on ordering complete fittings or alternative sealing materials see page I7.

*Please add the **suffixes** below according to the material/surface required.

Order code suffixes			
Material	Suffix surface and material	Example	Standard sealing material (no additional suffix needed)
Steel, zinc plated, Cr(VI)-free	CF	4RHDMTXSCF	NBR

RHV42EDMXS Non return valve

Male BSPP thread – ED-seal (ISO 1179) / Triple-Lok® 37° flare end

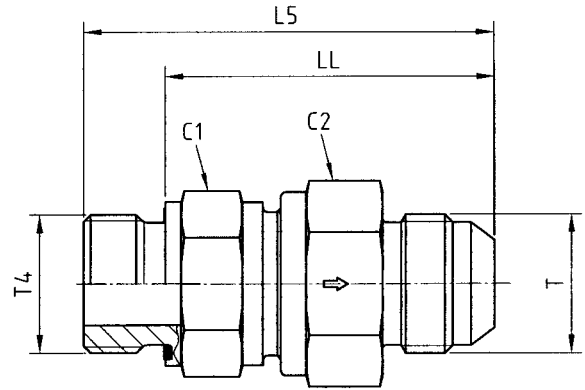

Tube O.D.		BSPP thread	Thread JIC SAE T	C1	C2	L5	LL	DN (Nom. diam.)	Weight g/1 piece	Order code*	PN (bar) ¹⁾	CF
mm	Inch	T4	T									
6	1/4	G 1/8	7/16-20 UNF	19	19	48.0	40.0	3.5	92	4RHV42EDMXS	420	
8	5/16	G 1/4	1/2-20 UNF	22	24	59.5	47.5	5.5	165	5-4RHV42EDMXS	420	
10	3/8	G 1/4	9/16-18 UNF	24	27	62.0	50.0	7.5	191	6RHV42EDMXS	420	
12	1/2	G 3/8	3/4-16 UNF	27	32	67.0	55.0	9.5	277	8RHV42EDMXS	420	
14, 15, 16	5/8	G 1/2	7/8-14 UNF	32	36	76.0	62.0	11.5	366	10RHV42EDMXS	350	
18, 20	3/4	G 3/4	1 1/16-12 UN	41	46	84.5	68.5	15.0	631	12RHV42EDMXS	350	
25	1	G 1	1 5/16-12 UN	46	50	89.5	71.5	19.0	863	16RHV42EDMXS	280	
28, 30, 32	1 1/4	G 1 1/4	1 5/8-12 UN	60	60	102.0	82.0	24.0	1403	20RHV42EDMXS	250	
35, 38	1 1/2	G 1 1/2	1 7/8-12 UN	65	70	113.0	91.0	29.0	1969	24RHV42EDMXS	210	

¹⁾Pressure shown = item deliverable

$$\frac{PN \text{ (bar)}}{10} = PN \text{ (MPa)}$$

Information on ordering complete fittings or alternative sealing materials see page I7.

*Please add the **suffixes** below according to the material/surface required.

Order code suffixes			
Material	Suffix surface and material	Example	Standard sealing material (no additional suffix needed)
Steel, zinc plated, Cr(VI)-free	CF	4RHV42EDMXSCF	NBR

RHZ42EDMXS Non return valve

Triple-Lok® 37° flare end / Male BSPP thread – ED-seal (ISO 1179)

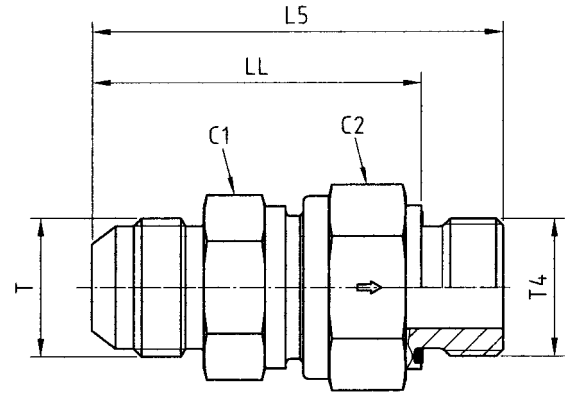

Tube O.D.		BSPP thread T4	Thread JIC SAE T	C1	C2	L5	LL	DN (Nom. diam.)	Weight g/1 piece	Order code*	PN (bar) ¹⁾
mm	Inch										CF
6	1/4	G 1/8	7/16-20 UNF	19	19	48.0	40.0	3.5	89	4RHZ42EDMXS	420
8	5/16	G 1/4	1/2-20 UNF	22	24	59.0	47.0	5.5	156	5-4RHZ42EDMXS	420
10	3/8	G 1/4	9/16-18 UNF	24	27	62.0	50.0	7.5	190	6RHZ42EDMXS	420
12	1/2	G 3/8	3/4-16 UNF	27	32	66.0	54.0	9.5	278	8RHZ42EDMXS	420
14, 15, 16	5/8	G 1/2	7/8-14 UNF	32	36	74.0	60.0	11.5	348	10RHZ42EDMXS	350
18, 20	3/4	G 3/4	1 1/16-12 UN	41	46	82.5	66.5	15.0	634	12RHZ42EDMXS	350
25	1	G 1	1 5/16-12 UN	46	50	89.5	71.5	19.0	863	16RHZ42EDMXS	280
28, 30, 32	1 1/4	G 1 1/4	1 5/8-12 UN	60	60	102.0	82.0	24.0	1397	20RHZ42EDMXS	250
35, 38	1 1/2	G 1 1/2	1 7/8-12 UN	65	70	115.0	93.0	29.0	2001	24RHZ42EDMXS	210

¹⁾Pressure shown = item deliverable

$$\frac{\text{PN (bar)}}{10} = \text{PN (MPa)}$$

Information on ordering complete fittings or alternative sealing materials see page I7.

Order code suffixes			
Material	Suffix surface and material	Example	Standard sealing material (no additional suffix needed)
Steel, zinc plated, Cr(VI)-free	CF	4RHZ42EDMXSCF	NBR

*Please add the **suffixes** below according to the material/surface required.

RHV5OMXS Non return valve

Male UN/UNF thread – O-ring (ISO 11926) / Triple-Lok® 37° flare end

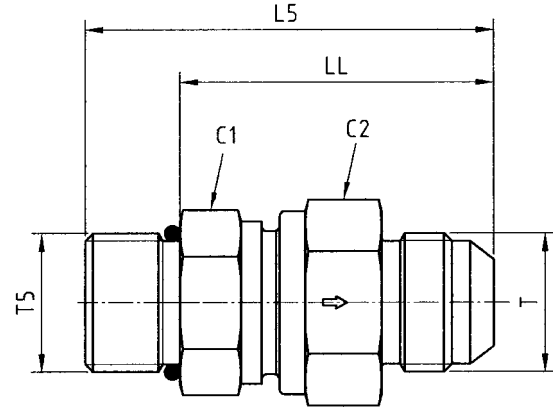

Tube O.D.		Thread UNF T5	Thread JIC SAE T	C1	C2	L5	LL	DN (Nom. diam.)	Weight g/1 piece	Order code*	PN (bar) ¹⁾
mm	Inch										CF
6	1/4	7/16-20 UNF	7/16-20 UNF	19	19	49.5	38.5	3.5	92	4RHV5OMXS	420
8	5/16	1/2-20 UNF	1/2-20 UNF	22	24	56.5	45.5	5.5	165	5RHV5OMXS	420
10	3/8	9/16-18 UNF	9/16-18 UNF	24	27	59.5	47.5	7.5	191	6RHV5OMXS	420
12	1/2	3/4-16 UNF	3/4-16 UNF	27	32	66.5	52.5	9.5	277	8RHV5OMXS	420
14, 15, 16	5/8	7/8-14 UNF	7/8-14 UNF	32	36	75.0	59.0	11.5	366	10RHV5OMXS	350
18, 20	3/4	1 1/16-12 UN	1 1/16-12 UN	41	46	84.0	65.5	15.0	631	12RHV5OMXS	350
25	1	1 5/16-12 UN	1 5/16-12 UN	46	50	88.0	69.5	19.0	863	16RHV5OMXS	280
28, 30, 32	1 1/4	1 5/8-12 UN	1 5/8-12 UN	60	60	99.5	81.0	24.0	1403	20RHV5OMXS	250
35, 38	1 1/2	1 7/8-12 UN	1 7/8-12 UN	65	70	109.5	91.0	29.0	1969	24RHV5OMXS	210

¹⁾Pressure shown = item deliverable

$$\frac{\text{PN (bar)}}{10} = \text{PN (MPa)}$$

Information on ordering complete fittings or alternative sealing materials see page I7.

*Please add the **suffixes** below according to the material/surface required.

Order code suffixes			
Material	Suffix surface and material	Example	Standard sealing material (no additional suffix needed)
Steel, zinc plated, Cr(VI)-free	CF	RHV5OMXSCF	NBR

RHZ5OMXS Non return valve

Triple-Lok® 37° flare end / Male UN/UNF thread – O-ring (ISO 11926)

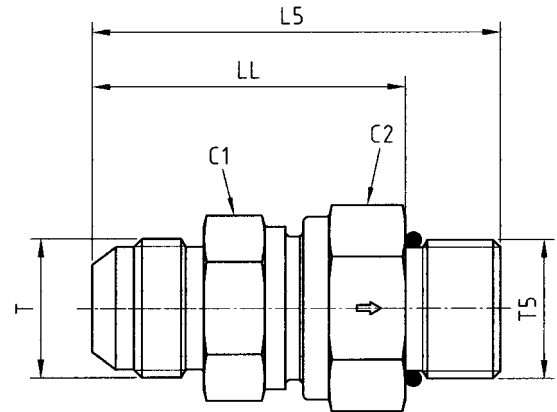

Tube O.D.		Thread UNF T5	Thread JIC SAE T	C1	C2	L5	LL	DN (Nom. diam.)	Weight g/1 piece	Order code*	PN (bar) ¹⁾
mm	Inch										CF
6	1/4	7/16-20 UNF	7/16-18 UNF	19	19	49.5	38.5	3.5	91	4RHZ5OMXS	420
8	5/16	1/2-20 UNF	1/2-20 UNF	22	24	56.5	45.5	5.5	161	5RHZ5OMXS	420
10	3/8	9/16-18 UNF	9/16-18 UNF	24	27	59.5	47.5	7.5	190	6RHZ5OMXS	420
12	1/2	3/4-16 UNF	3/4-16 UNF	27	32	66.5	52.5	9.5	278	8RHZ5OMXS	420
14, 15, 16	5/8	7/8-14 UNF	7/8-14 UNF	32	36	75.0	59.0	11.5	348	10RHZ5OMXS	350
18, 20	3/4	1 1/16-12 UN	1 1/16-12 UN	41	46	84.0	65.5	15.0	634	12RHZ5OMXS	350
25	1	1 5/16-12 UN	1 5/16-12 UN	46	50	88.0	69.5	19.0	863	16RHZ5OMXS	280
28, 30, 32	1 1/4	1 5/8-12 UN	1 5/8-12 UN	60	60	107.0	81.0	24.0	1397	20RHZ5OMXS	250
35, 38	1 1/2	1 7/8-12 UN	1 7/8-12 UN	65	70	109.5	91.0	29.0	2001	24RHZ5OMXS	210

¹⁾Pressure shown = item deliverable

$$\frac{\text{PN (bar)}}{10} = \text{PN (MPa)}$$

Information on ordering complete fittings or alternative sealing materials see page I7.

*Please add the **suffixes** below according to the material/surface required.

Order code suffixes			
Material	Suffix surface and material	Example	Standard sealing material (no additional suffix needed)
Steel, zinc plated, Cr(VI)-free	CF	4RHZ5OMXS ^{CF}	NBR

RHV82EDMXS Non return valve

Male metric thread – ED-seal (ISO 9974) / Triple-Lok® 37° flare end

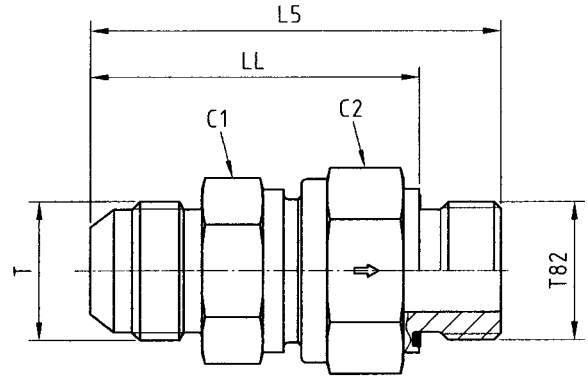

Tube O.D.		Metric thread T82	Thread JIC SAE T	C1	C2	L5	LL	DN (Nom. diam.)	Weight g/1 piece	Order code*	PN (bar) ¹⁾
mm	Inch										CF
6	1/4	M 10×1.0	7/16-20 UNF	19	19	48.0	40.0	3.5	89	4M10RHV82EDMXS	420
8	5/16	M 12×1.5	1/2-20 UNF	22	24	59.5	47.5	5.5	157	5M12RHV82EDMXS	420
10	3/8	M 14×1.5	9/16-18 UNF	24	27	62.0	50.0	7.5	195	6M14RHV82EDMXS	420
12	1/2	M 16×1.5	3/4-16 UNF	27	32	67.0	55.0	9.5	274	8M16RHV82EDMXS	420
14, 15, 16	5/8	M 18×1.5	7/8-14 UNF	32	36	73.5	61.5	11.5	369	10M18RHV82EDMXS	350
18, 20	3/4	M 27×2.0	1 1/16-12 UN	41	46	84.5	68.5	15.0	628	12M27RHV82EDMXS	350
25	1	M 33×2.0	1 5/16-12 UN	46	50	89.5	71.5	19.0	867	16M33RHV82EDMXS	280
28, 30, 32	1 1/4	M 42×2.0	1 5/8-12 UN	60	60	102.0	82.0	24.0	1409	20M42RHV82EDMXS	250
35, 38	1 1/2	M 48×2.0	1 7/8-12 UN	65	70	113.0	91.0	29.0	1970	24M48RHV82EDMXS	210

¹⁾Pressure shown = item deliverable

$$\frac{\text{PN (bar)}}{10} = \text{PN (MPa)}$$

Information on ordering complete fittings or alternative sealing materials see page I7.

*Please add the **suffixes** below according to the material/surface required.

Order code suffixes			
Material	Suffix surface and material	Example	Standard sealing material (no additional suffix needed)
Steel, zinc plated, Cr(VI)-free	CF	4M10RHV82EDMXSCF	NBR

RHZ82EDMXS Non return valve

Triple-Lok® 37° flare end / Male metric thread – ED-seal (ISO 9974)

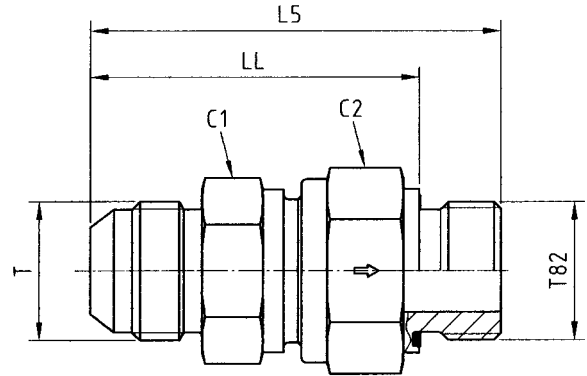

Tube O.D.		Metric thread T82	Thread JIC SAE T	C1	C2	L5	LL	DN (Nom. diam.)	Weight g/1 piece	Order code*	PN (bar) ¹⁾
mm	Inch										CF
6	1/4	M 10×1.0	7/16-20 UNF	19	19	48.0	40.0	3.5	89	4M10RHZ82EDMXS	420
8	5/16	M 12×1.5	1/2-20 UNF	22	24	59.5	47.5	5.5	156	5M12RHZ82EDMXS	420
10	3/8	M 14×1.5	9/16-18 UNF	24	27	62.0	50.0	7.5	195	6M14RHZ82EDMXS	420
12	1/2	M 16×1.5	3/4-16 UNF	27	32	66.0	54.0	9.5	272	8M16RHZ82EDMXS	420
14, 15, 16	5/8	M 18×1.5	7/8-14 UNF	32	36	71.5	59.5	11.5	352	10M18RHZ82EDMXS	350
18, 20	3/4	M 27×2.0	1 1/16-12 UN	41	46	82.5	66.5	15.0	608	12M27RHZ82EDMXS	350
25	1	M 33×2.0	1 5/16-12 UN	46	50	89.5	71.5	19.0	965	16M33RHZ82EDMXS	280
28, 30, 32	1 1/4	M 42×2.0	1 5/8-12 UN	60	60	102.0	82.0	24.0	1396	20M42RHZ82EDMXS	250
35, 38	1 1/2	M 48×2.0	1 7/8-12 UN	65	70	115.0	93.0	29.0	1807	24M48RHZ82EDMXS	210

¹⁾Pressure shown = item deliverable

$$\frac{\text{PN (bar)}}{10} = \text{PN (MPa)}$$

Information on ordering complete fittings or alternative sealing materials see page I7.

*Please add the **suffixes** below according to the material/surface required.

Order code suffixes			
Material	Suffix surface and material	Example	Standard sealing material (no additional suffix needed)
Steel, zinc plated, Cr(VI)-free	CF	4M10RHZ82EDMXSCF	NBR

KH 2-way ball valve steel

EO 24° cone end / EO 24° cone end

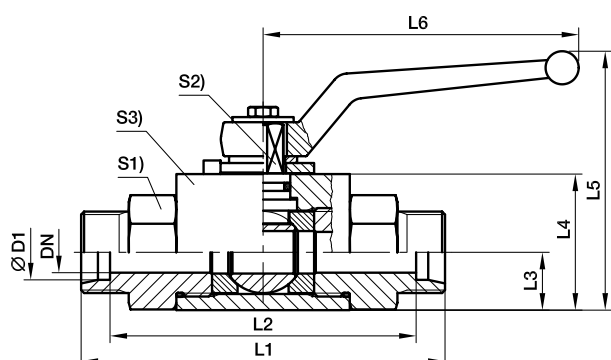

DN 4-25

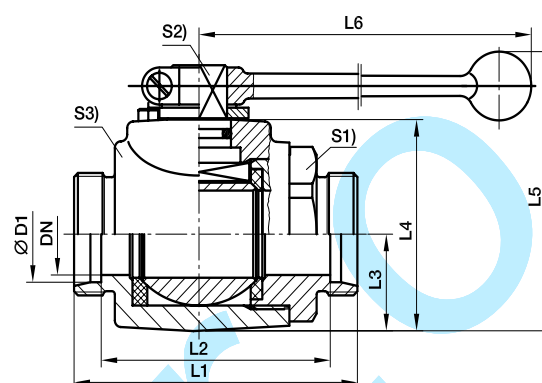
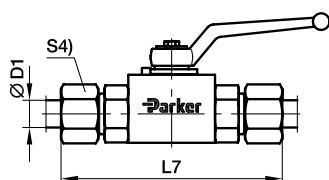

DN 32-40

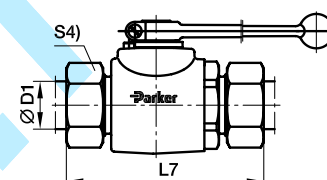

Series	D1	DN	L1	L2	L3	L4	L5	L6	L7	S1	S2	S3	S4	Weight g/1 piece	Order code*	PN (bar) ¹⁾	
L ³⁾	06	4	67	53	10.0	25	55.0	76	82	19	7	20	14	195	KH06LX	500	
	08	6	67	53	10.0	25	55.0	76	82	19	7	20	17	190	KH08LX	500	
	10	8	75	61	14.5	35	68.0	100	90	24	8	30	19	420	KH10LX	500	
	12	10	75	61	14.5	35	68.0	100	90	24	8	30	22	410	KH12LX	500	
	15	12	83	69	17.0	40	92.0	113	99	30	10	35	27	631	KH15LX	500	
	18	16	82	67	20.0	45	105.0	113	99	36	11	45	32	850	KH18LX	400	
	22	20	99	84	24.0	55	113.0	187	116	41	14	45	36	1210	KH22LX	400	
	28	25	108	93	26.0	60	118.0	187	126	50	14	55	41	1750	KH28LX	400	
	35	25	116	95	26.0	60	118.0	187	138	50	14	55	50	1820	KH35LDN25X	400	
	35	32	121	100	36.5	80	180.5	320	143	60	17	73	50	3158	KH35LX	315	
	42	25	121	99	26.0	60	118.0	187	144	55	14	55	60	1940	KH42LDN25X	400	
	42	40	118	96	42.5	90	190.5	320	141	70	17	85	60	3788	KH42LX	315	
	S ⁴⁾	08	4	73	59	10.0	25	55.0	76	88	19	7	20	19	214	KH08SX	500
		10	6	73	58	10.0	25	55.0	76	90	19	7	20	22	220	KH10SX	500
12		8	77	62	14.5	35	68.0	100	94	24	8	30	24	430	KH12SX	500	
14		10	81	65	14.5	35	68.0	100	100	24	8	30	27	440	KH14SX	500	
16		12	87	70	17.0	40	92.0	113	106	30	10	35	30	649	KH16SX	500	
20		16	90	69	20.0	45	105.0	113	112	36	11	45	36	900	KH20SX	400	
25		20	107	83	24.0	55	113.0	187	131	41	14	45	46	1290	KH25SX	400	
30		25	120	93	26.0	60	118.0	187	146	50	14	55	50	1880	KH30SX	400	
38		25	134	102	26.0	60	118.0	187	163	55	14	55	60	1950	KH38SDN25X	400	
38		32	127	95	36.5	80	180.5	320	156	60	17	73	60	3266	KH38SX	315	

¹⁾ Pressure shown = item deliverable

³⁾ L = light series; ⁴⁾ S = heavy series

$$\frac{\text{PN (bar)}}{10} = \text{PN (MPa)}$$

Delivery without nut and ring. Information on ordering complete fittings or alternative sealing materials see page 17.

Order code suffixes			
Material	Suffix surface and material	Example	Standard sealing material (no additional suffix needed)
Steel, zinc plated, Cr(VI)-free	CF	KH06LCFX	POM / NBR
Steel	DIN 50938-FE//A/T4	KH06LX	POM / NBR

KH 2-way ball valve stainless steel

EO 24° cone end / EO 24° cone end

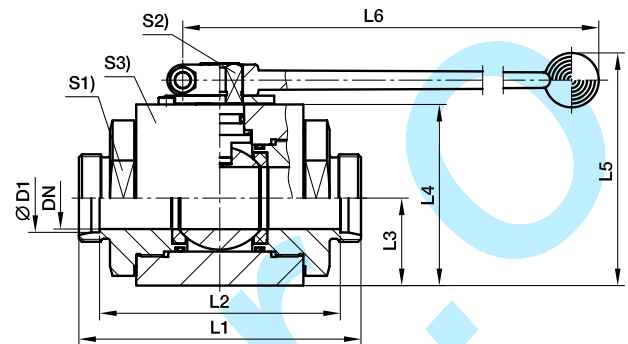
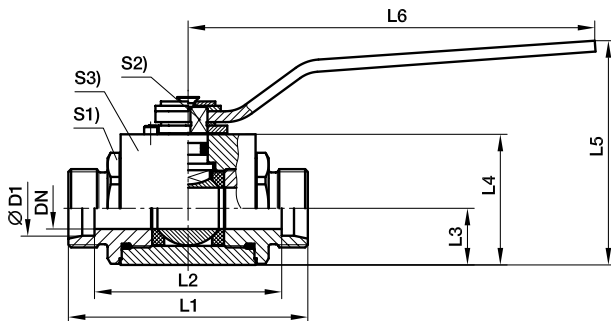

DN 4-25

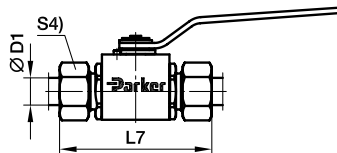

DN 32-40

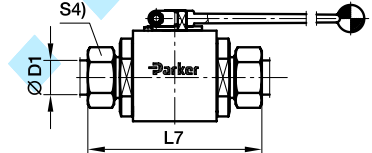

Series	D1 	DN	L1	L2	L3	L4	L5	L6	L7	S1	S2	S3	S4	Weight g/1 piece	Order code*	PN (bar) ¹⁾ 71
L ³⁾	06	4	73	59	13.7	30.0	56.5	76	88	22	7	30	14	383	KH06L71X	500
	08	6	73	59	13.7	30.0	56.5	76	88	22	7	30	17	381	KH08L71X	500
	10	8	87	73	18.0	40.0	84.5	130	102	30	8	40	19	809	KH10L71X	500
	12	10	87	73	18.0	40.0	84.5	130	102	30	8	40	22	821	KH12L71X	500
	15	12	91	77	21.0	45.0	90.0	130	107	32	10	45	27	1020	KH15L71X	500
	18	16/12	91	76	21.0	45.0	90.0	130	108	32	10	45	32	1037	KH18L71X	500
	22	20	105	87	31.0	65.0	115.0	185	119	46	14	65	36	1610	KH22L71X	420
	28	25	112	92	38.0	75.0	125.0	185	125	50	14	75	41	2032	KH28L71X	420
	35	32	145	124	45.0	93.2	175.0	320	148	70	19	100	50	4780	KH35L71X	420
	42	40	150	114	52.5	104.4	186.0	320	159	80	19	110	60	7754	KH42L71X	420
S ⁴⁾	08	4	76	62	13.7	30.0	56.5	76	91	22	7	30	19	392	KH08S71X	500
	10	6	76	61	13.7	30.0	56.5	76	93	22	7	30	22	460	KH10S71X	500
	12	8	89	74	18.0	40.0	84.5	130	106	30	8	40	24	840	KH12S71X	500
	14	10	93	77	18.0	40.0	84.5	130	112	30	8	40	27	847	KH14S71X	500
	16	12	96	79	21.0	45.0	90.0	130	115	32	10	45	30	1055	KH16S71X	500
	20	16/12	99	78	21.0	45.0	90.0	130	121	32	10	45	36	1079	KH20S71X	500
	25	20	113	86	31.0	65.0	115.0	185	134	46	14	65	46	1720	KH25S71X	420
	30	25	124	93	38.0	75.0	125.0	185	146	50	14	75	50	2150	KH30S71X	420
	38	32	145	100	45.0	93.2	175.0	320	161	70	19	100	60	6066	KH38S71X	420

¹⁾ Pressure shown = item deliverable

³⁾ L = light series; ⁴⁾ S = heavy series

$\frac{\text{PN (bar)}}{10} = \text{PN (MPa)}$

Delivery without nut and ring. Information on ordering complete fittings or alternative sealing materials see page 17.

*Please add the **suffixes** below according to the material/surface required.

Order code suffixes			
Material	Suffix surface and material	Example	Standard sealing material (no additional suffix needed)
Stainless Steel	without	KH06L71X	POM / NBR

KH 2-way BSPP ball valve steel

Female BSPP thread (ISO 1179-1) / Female BSPP thread (ISO 1179-1)

DN 4-25

DN 32-40

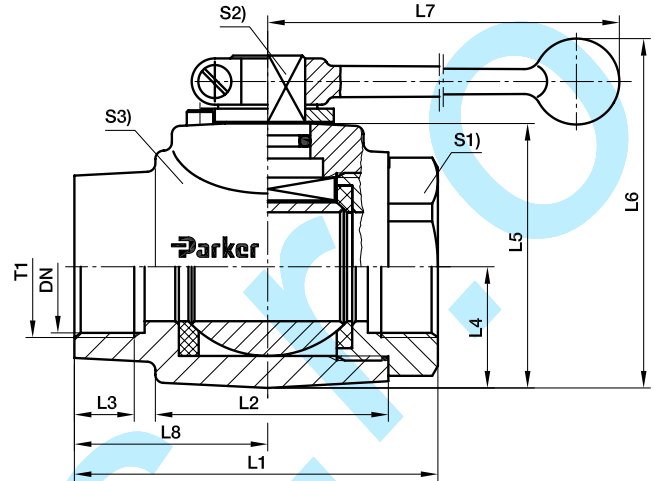
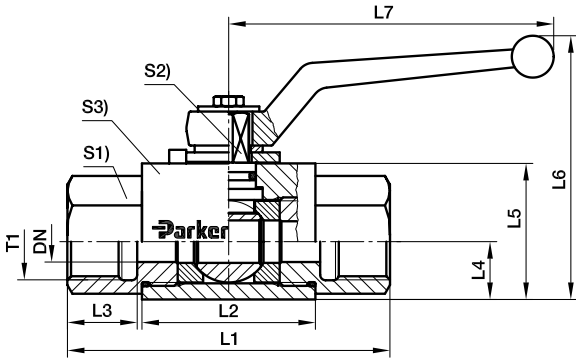

T1	DN	L1	L2	L3	L4	L5	L6	L7	L8	S1	S2	S3	Weight g/1 piece	Order code*	PN (bar) ¹⁾
G 1/8	4	69	36.0	12.0	10.0	25	55.0	76	-	19	7	20	220	KH1/8X	500
G 1/4	6	69	36.0	12.0	10.0	25	55.0	76	-	19	7	20	210	KH1/4X	500
G 3/8	10	73	45.0	14.0	14.5	35	68.0	100	-	24	8	30	430	KH3/8X	500
G 1/2	12	82	51.0	15.0	17.0	40	92.0	112	-	30	10	35	670	KH1/2X	500
G 5/8	16	88	50.0	18.0	20.0	45	105.0	166	-	36	11	45	973	KH5/8X	400
G 3/4	20	93	60.0	18.0	24.0	55	113.0	187	-	41	14	45	1280	KH3/4X	400
G 1	25	113	70.0	20.0	26.0	60	118.0	187	-	50	14	55	1982	KH1X	400
G 1 1/4	32	110	70.0	20.0	36.5	80	180.5	320	58.5	60	17	73	2620	KH11/4X	315
G 1 1/4	25	134	70.0	20.0	26.0	60	118.0	187	-	50	14	55	2066	KH11/4DN25X	400
G 1 1/2	40	114	75.0	22.0	42.5	90	190.5	320	57.0	70	17	85	3989	KH11/2X	315
G 1 1/2	25	139	70.0	22.0	26.0	60	118.0	187	-	55	14	55	2200	KH11/2DN25X	400
G 2	50	129	91.5	27.5	49.5	104	180.0	320	65.0	85	17	99	5020	KH2X	400

¹⁾ Pressure shown = item deliverable

$$\frac{\text{PN (bar)}}{10} = \text{PN (MPa)}$$

Delivery without nut and ring. Information on ordering complete fittings or alternative sealing materials see page 17.

Order code suffixes			
Material	Suffix surface and material	Example	Standard sealing material (no additional suffix needed)
Steel, zinc plated, Cr(VI)-free	CF	KH1/8CFX	POM / NBR
Steel	DIN 50938-FE//A/T4	KH1/8X	POM / NBR

KH 2-way BSPP ball valve stainless steel

Female BSPP thread (ISO 1179-1) / Female BSPP thread (ISO 1179-1)

DN 4-25

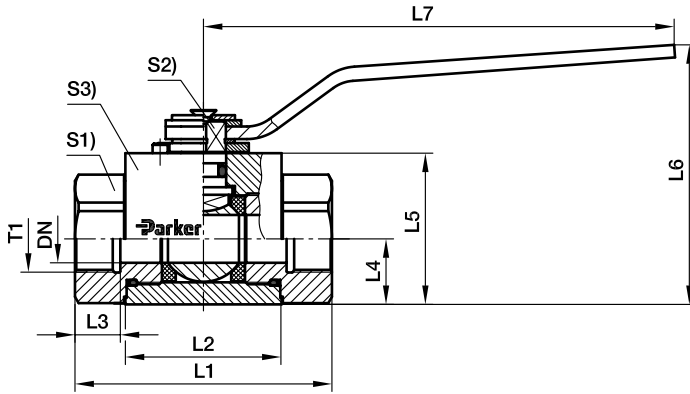

DN 32-40

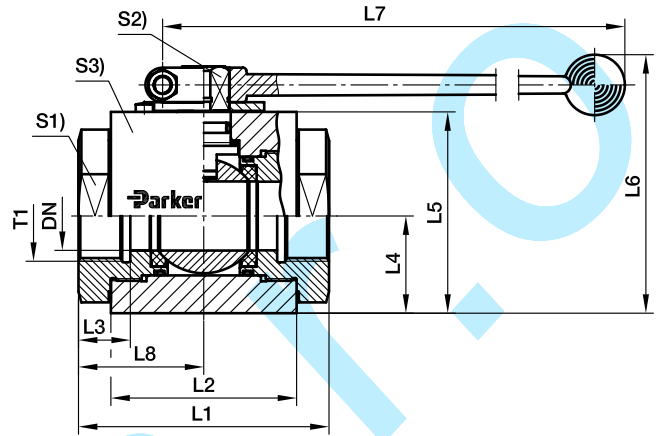

T1	DN	L1	L2	L3	L4	L5	L6	L7	L8	S1	S2	S3	Weight g/1 piece	Order code*	PN(bar) ¹⁾ 71
G 1/8	4	69	41	11	13.7	30.0	56.5	76	-	22	7	30	421	KH1/871X	500
G 1/4	6	75	41	14	13.7	30.0	56.5	76	-	22	7	30	422	KH1/471X	500
G 3/8	10	86	53	14	18.0	40.0	84.5	130	-	30	8	40	891	KH3/871X	500
G 1/2	12	92	55	16	21.0	45.0	90.0	130	-	32	10	45	1093	KH1/271X	500
G 3/4	20	111	65	18	31.0	65.0	115.0	185	-	46	14	65	1944	KH3/471X	420
G 1	25	122	71	20	38.0	75.0	125.0	185	-	50	14	75	2200	KH171X	420
G 1 1/4	32	110	86	24	45.0	93.2	175.0	320	55	70	19	100	5300	KH11/471X	420
G 1 1/2	40	120	92	26	52.2	104.4	186.0	320	60	80	19	110	7230	KH11/271X	420

¹⁾ Pressure shown = item deliverable

$$\frac{PN(\text{bar})}{10} = PN(\text{MPa})$$

Delivery without nut and ring. Information on ordering complete fittings or alternative sealing materials see page I7.

*Please add the **suffixes** below according to the material/surface required.

Order code suffixes			
Material	Suffix surface and material	Example	Standard sealing material (no additional suffix needed)
Stainless Steel	without	KH1/871X	POM / NBR

KH 2-way NPT ball valve steel

Female NPT thread (SAE 476) / Female NPT thread (SAE 476)

DN 4-25

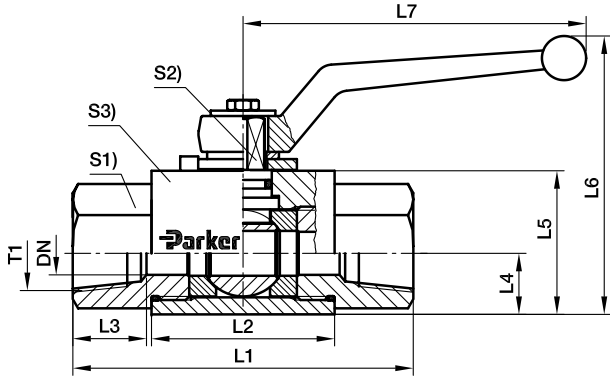

DN 32-40

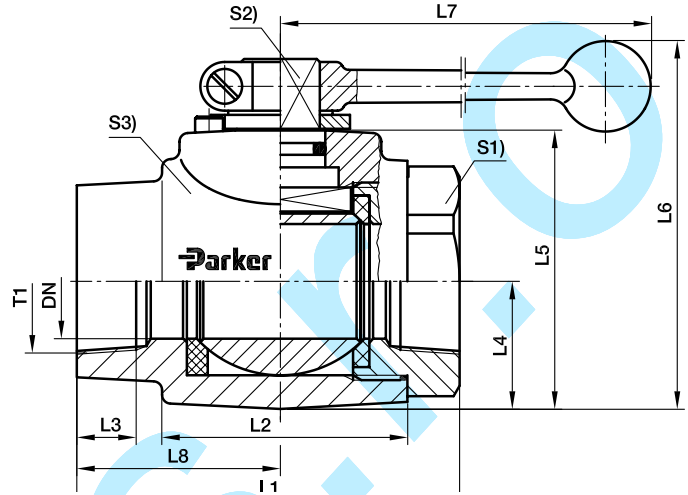

T1	DN	L1	L2	L3	L4	L5	L6	L7	L8	S1	S2	S3	Weight g/1 piece	Order code*	PN (bar) ¹⁾
1/8-27 NPT	4	69	36	7.0	10.0	25	55.0	76	-	19	7	20	225	KH1/8NPTX	500
1/4-18 NPT	6	69	36	10.0	10.0	25	55.0	76	-	19	7	20	210	KH1/4NPTX	500
3/8-18 NPT	10	73	45	10.4	14.5	35	68.0	100	-	24	8	30	430	KH3/8NPTX	500
1/2-14 NPT	12	82	51	13.6	17.0	40	92.0	112	-	30	10	35	670	KH1/2NPTX	500
3/4-14 NPT	20	93	60	14.0	24.0	55	113.0	187	-	41	14	45	1280	KH3/4NPTX	400
1-11.5 NPT	25	113	70	16.8	26.0	60	118.0	187	-	50	14	55	1970	KH1NPTX	400
1 1/4-11.5 NPT	32	110	70	17.3	36.5	80	180.5	320	58.5	60	17	73	3074	KH11/4NPTX	315
1 1/2-11.5 NPT	40	114	75	17.3	42.5	90	190.5	320	57.0	70	17	85	3976	KH11/2NPTX	315

¹⁾Pressure shown = item deliverable

$$\frac{PN \text{ (bar)}}{10} = PN \text{ (MPa)}$$

Delivery without nut and ring. Information on ordering complete fittings or alternative sealing materials see page I7.

Order code suffixes			
Material	Suffix surface and material	Example	Standard sealing material (no additional suffix needed)
Steel, zinc plated, Cr(VI)-free	CF	KH1/8NPTCFX	POM / NBR
Steel	DIN 50938-FE//A/T4	KH1/8NPTX	POM / NBR

KH 2-way NPT ball valve stainless steel

Female NPT thread (SAE 476) / Female NPT thread (SAE 476)

DN 4-25

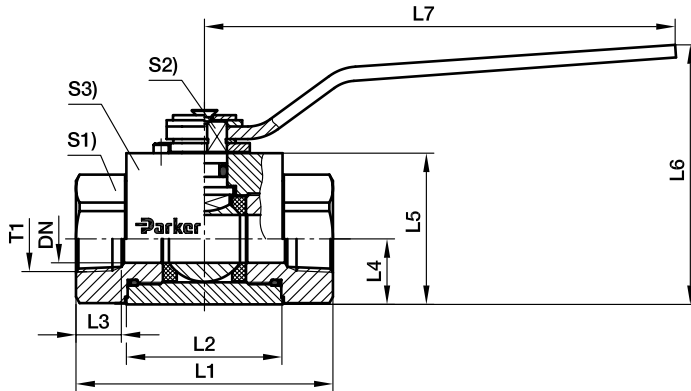

DN 32-40

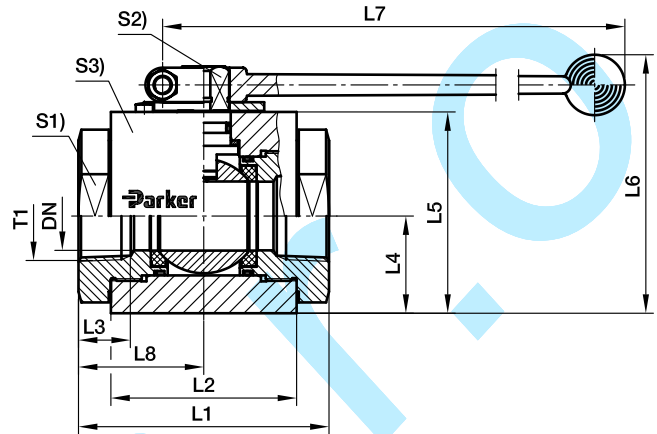

T1	DN	L1	L2	L3	L4	L5	L6	L7	L8	S1	S2	S3	Weight g/1 piece	Order code*	PN (bar) ¹⁾ 71
1/8-27 NPT	4	82	41	6.9	13.7	30.0	56.5	76		22	7	30	461	KH1/8NPT71X	500
1/4-18 NPT	6	82	41	10.0	13.7	30.0	56.5	76		22	7	30	441	KH1/4NPT71X	500
3/8-18 NPT	10	95	53	10.3	18.0	40.0	84.5	130		30	8	40	943	KH3/8NPT71X	500
1/2-14 NPT	12	108	55	13.6	21.0	45.0	90.0	130		32	10	45	1177	KH1/2NPT71X	500
3/4-14 NPT	20	111	65	14.1	31.0	65.0	115.0	185		46	14	65	2054	KH3/4NPT71X	420
1-11.5 NPT	25	122	71	16.8	38.0	75.0	125.0	185		50	14	75	2451	KH1NPT71X	420
1 1/4-11.5 NPT	32	110	86	17.3	45.0	93.2	175.0	320	55	70	19	100	5300	KH11/4NPT71X	420
1 1/2-11.5 NPT	40	120	92	17.7	52.2	104.4	186.0	320	60	80	19	110	7230	KH11/2NPT71X	420

¹⁾ Pressure shown = item deliverable

$$\frac{PN \text{ (bar)}}{10} = PN \text{ (MPa)}$$

Delivery without nut and ring. Information on ordering complete fittings or alternative sealing materials see page 17.

*Please add the **suffixes** below according to the material/surface required.

Order code suffixes			
Material	Suffix surface and material	Example	Standard sealing material (no additional suffix needed)
Stainless steel	without	KH1/8NPT71X	POM / NBR

KH 3-way compact ball valve steel

EO 24° cone end / EO 24° cone end / EO 24° cone end

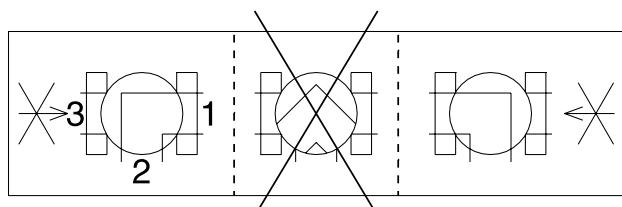
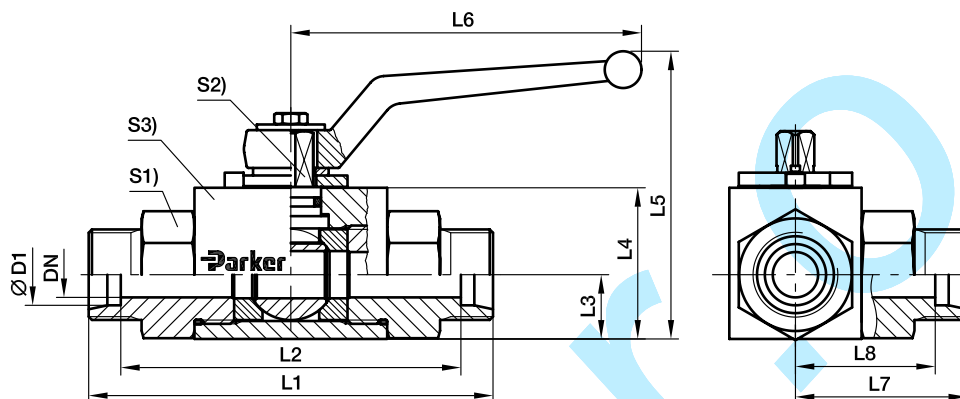

L-Version

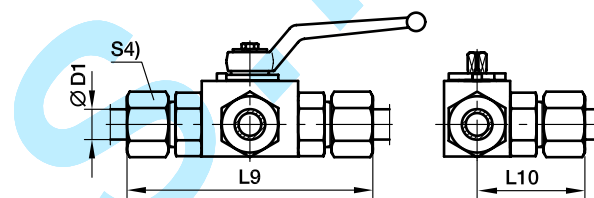

Series	D1 DN	L1	L2	L3	L4	L5	L6	L7	L8	L9	L10	S1	S2	S3	S4	Weight g/1 piece	Order code*	PN (bar) ¹⁾	
L ³⁾	06	4	67	53	15.0	30	59.5	76	33.5	26.5	82	41.0	19	7	30	14	317	KH3/2-06LX	500
	08	6	67	53	15.0	30	59.5	76	33.5	26.5	82	41.0	19	7	30	17	214	KH3/2-08LX	500
	10	8	75	61	14.5	35	67.5	100	37.5	30.5	90	45.0	24	8	40	19	445	KH3/2-10LX	500
	12	10	75	61	14.5	35	67.5	100	37.5	30.5	90	45.0	24	8	40	22	537	KH3/2-12LX	500
	15	12	83	69	22.0	45	96.5	112	41.5	34.5	99	49.5	30	10	45	27	678	KH3/2-15LX	500
	18	16	82	67	25.0	50	110.0	166	41.0	33.5	99	49.5	36	11	50	32	850	KH3/2-18LX	400
S ⁴⁾	22	20	99	84	29.0	60	126.0	187	49.5	42.0	116	58.0	41	14	55	36	1340	KH3/2-22LX	400
	28	25	108	93	31.0	65	131.0	187	54.0	46.5	126	63.0	50	14	65	41	2274	KH3/2-28LX	400
	08	4	73	59	15.0	30	59.5	76	36.5	29.5	88	44.0	19	7	30	19	350	KH3/2-08SX	500
	10	6	73	58	15.0	30	59.5	76	36.5	29.0	90	45.0	19	7	30	22	300	KH3/2-10SX	500
	12	8	77	62	14.5	35	67.5	100	38.5	31.0	94	47.0	24	8	40	24	469	KH3/2-12SX	500
	14	10	81	65	14.5	35	67.5	100	40.5	32.5	100	50.0	24	8	40	27	500	KH3/2-14SX	500
	16	12	87	70	22.0	45	96.5	112	43.5	35.0	106	53.0	30	10	45	30	909	KH3/2-16SX	500
	20	16	90	69	25.0	50	110.0	166	45.0	34.5	112	56.0	36	11	50	36	949	KH3/2-20SX	400
	25	20	107	83	29.0	60	126.0	187	53.5	41.5	131	65.5	41	14	55	46	1714	KH3/2-25SX	400
	30	25	120	93	31.0	65	131.0	187	60.0	46.5	146	73.0	50	14	65	50	2462	KH3/2-30SX	400

¹⁾ Pressure shown = item deliverable

³⁾ L = light series; ⁴⁾ S = heavy series

PN (bar) = PN (MPa) / 10

Delivery without nut and ring. Information on ordering complete fittings or alternative sealing materials see page 17.

Order code suffixes			
Material	Suffix surface and material	Example	Standard sealing material (no additional suffix needed)
Steel, zinc plated, Cr(VI)-free	CF	KH3/2-06LCFX	POM / NBR
Steel	DIN 50938-FE//A/T4	KH3/2-06LX	POM / NBR

KH 3-way compact BSPP ball valve steel

Female BSPP thread (ISO 1179-1) / Female BSPP thread (ISO 1179-1) /
Female BSPP thread (ISO 1179-1)

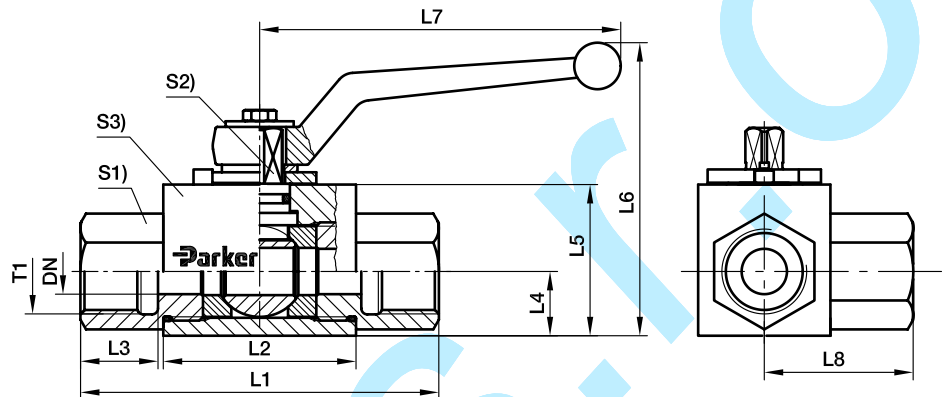

T1	DN	L1	L2	L3	L4	L5	L6	L7	L8	S1	S2	S3	Weight g/1 piece	Order code*	PN (bar) ¹⁾
G 1/8	4	69	36	12	15.0	30	55	76	34.5	19	7	30	270	KH3/2-1/8X	500
G 1/4	6	69	36	12	15.0	30	55	76	34.5	19	7	30	342	KH3/2-1/4X	500
G 3/8	10	73	45	14	14.5	35	68	100	36.5	24	8	40	563	KH3/2-3/8X	500
G 1/2	12	82	51	15	22.0	45	92	112	41.0	30	10	45	932	KH3/2-1/2X	500
G 3/4	20	93	60	18	29.0	60	113	187	48.0	41	14	55	1724	KH3/2-3/4X	400
G 1	25	118	70	18	31.0	65	119	187	57.5	50	14	65	2643	KH3/2-1X	400
G 1 1/4	32/25	134	70	20	31.0	65	119	187	67.0	50	14	65	2710	KH3/2-11/4X	400
G 1 1/2	40/25	139	70	22	31.0	65	119	187	69.5	50	14	65	2910	KH3/2-11/2X	400

¹⁾ Pressure shown = item deliverable

$$\frac{PN \text{ (bar)}}{10} = PN \text{ (MPa)}$$

Delivery without nut and ring. Information on ordering complete fittings or alternative sealing materials see page I7.

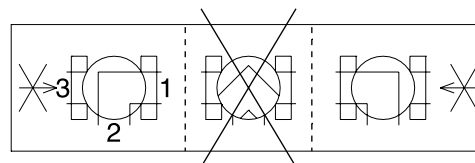

L-Version

Order code suffixes			
Material	Suffix surface and material	Example	Standard sealing material (no additional suffix needed)
Steel, zinc plated, Cr(VI)-free	CF	KH3/2-1/8CFX	POM / NBR
Steel	DIN 50938-FE//A/T4	KH3/2-1/8X	POM / NBR

KH – Locking Devices for 2/2 Way and Multiway ball valves

with floating ball – steel and stainless steel

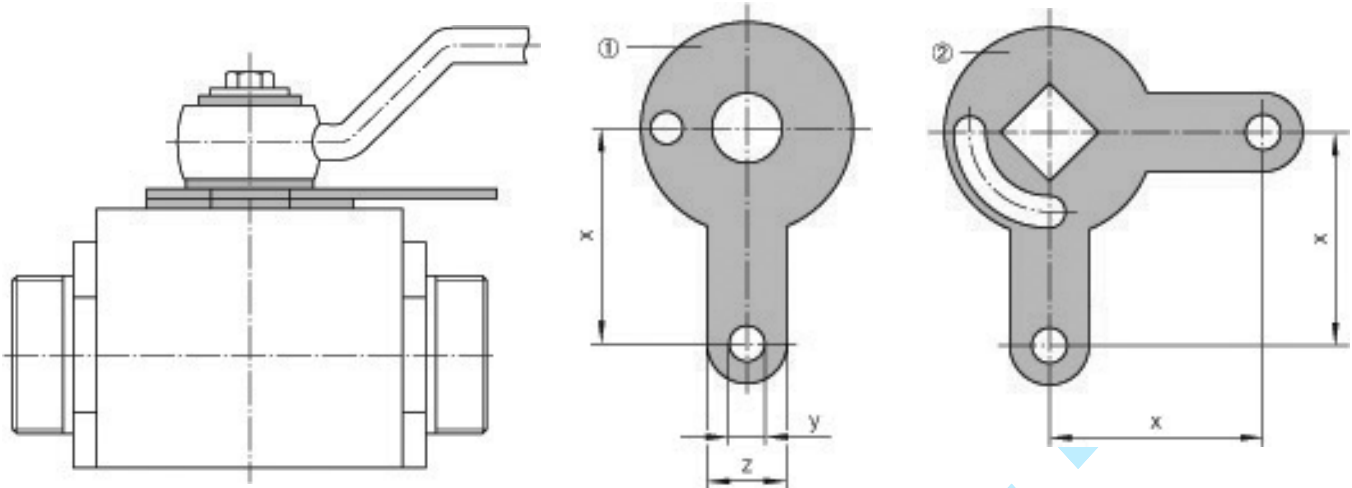

DN	t	x	y	z	X	Order code Steel	Order code Stainless steel
4/6	0.80	18	9	20	21.5	KHLOCKINGD.SIZE1X	KHLOCKINGD.SIZE171X
8/10	1.20	21	9	20	26.5	KHLOCKINGD.SIZE2X	KHLOCKINGD.SIZE271X
12	1.20	24	9	20	29.0	KHLOCKINGD.SIZE3X	KHLOCKINGD.SIZE371X
16	1.50	29	9	20	–	KHLOCKINGD.SIZE4X	–
20/25	1.50	34	9	20	44.0	KHLOCKINGD.SIZE5X	KHLOCKINGD.SIZE571X
32/40/50	1.75	54	9	20	54.0	KHLOCKINGD.SIZE6X	KHLOCKINGD.SIZE671X

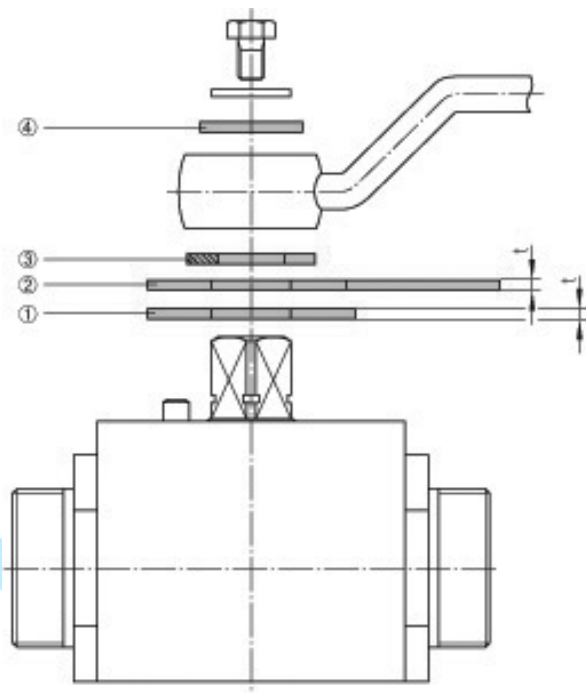

mounting kit:

- ① = mounting plate
- ② = limit stop plate
- ③ = safety ring
- ④ = disk

Pos. ④ only for DN32/40/50

Switching positions

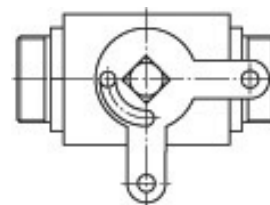

KH-B1V-S Ball valve with SAE Flange connection (6000 PSI)

SAE Flange (ISO 6162-1/-2) / Ball valve 2/2 way steel

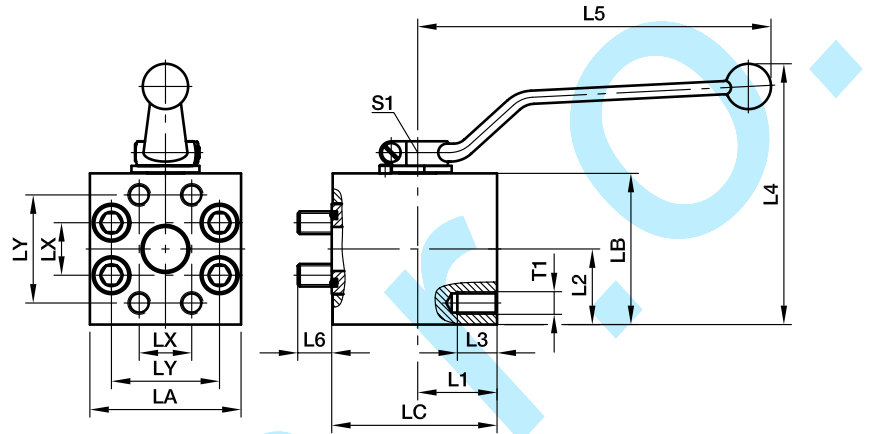
6000 PSI Series

Nom. flange size															Screws		Weight	PN	
SAE (in)	ISO (DN)	L1	L2	L3	L4	L5	L6	LX	LY	LA	LB	LC	S1	T1	(metr.)	O-ring	kg/piece	Order code*	(bar) ¹⁾ S
1/2	12	32.0	28.5	19	107	112	13.5	18.2	40.5	60	55	60.5	10	M 8	M 08×65	18.66×3.53	1.29	KH12B1V62	420
3/4	20	31.0	35.0	16	134	187	14.0	23.8	50.8	70	70	62.5	14	M10	M 10×65	25.00×3.53	2.15	KH20B1V63	420
1	25	39.0	40.0	21	144	187	18.0	27.8	57.2	80	80	75.5	14	M12	M 12×80	32.92×3.53	2.95	KH25B1V64	420
1 1/4	32	43.5	50.0	23	129	320	18.0	31.8	66.7	100	100	82.0	17	M12*	M 12×85	37.70×3.53	6.21	KH32B1V65	420
1 1/2	40	53.5	60.0	26	149	320	18.0	36.5	79.4	120	120	99.0	17	M16	M 16×100	47.22×3.53	9.50	KH40B1V66	420
2	50	61.0	61.5	34	153	320	22.0	44.5	96.8	134	124	109.5	17	M20	M 20×100	56.74×3.53	12.80	KH50B1V68	420

¹⁾Pressure shown = Item deliverable

The pressure specification PN for quarter turn ball valves applies to the design factor 1.5 (according DIN 3230 T5 and ISO 5208).

$$\frac{PN \text{ (bar)}}{10} = PN \text{ (MPa)}$$

 *M14 deliverable on request. **KH32B1V65/14**
Materials:

Body made of steel, coating DIN 50938-FE/A/T4, ball of hard chrome plated carbon steel, stem of zinc plated steel.

Seals:

Ball seat of POM (e.g. Delrin), stem seal of NBR (e.g. Perbunan).

Applications:

Suitable for petroleum-based hydraulic fluid, lubricants and fuel oil. For air applications suitable up to 100 bar.

Temperature range:

-10 up to +100° C

Order code suffixes			
Material	Suffix surface and material	Example	Standard sealing material (no additional suffix needed)
Steel, zinc plated, Cr(VI)-free	CF	KH12B1V62CFX	POM / NBR
Steel	DIN 50938-FE//A/T4	KH12B1V62X	POM / NBR

KH-B2V-S Ball valve with SAE Flange connection (block 3000/6000 PSI)

SAE Flange / Ball valve 2/2 way steel
(ISO 6162-1/-2)

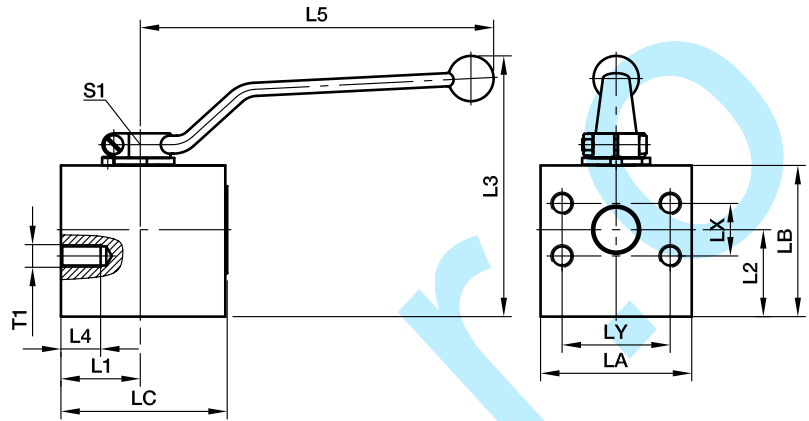

3000 PSI Series

Nom. flange size		T1		L1	L2	L3	L4	L5	LX	LY	LA	LB	LC	S1	Weight (steel) kg/piece	Order code*	PN (bar) ¹⁾ S
SAE (in)	ISO (DN)	(metr.)	(in)														
1/2	12	M 8	5/16-18 UNC	23.5	22	97	17	112	17.5	38.1	55	45	60	10	1.1	KH12B2V32	210
3/4	20	M10	3/8-16 UNC	39.5	39	128	21	187	22.2	47.6	70	70	80	14	2.8	KH20B2V33	210
1	25	M12	3/8-16 UNC	42.0	46	138	19	187	26.2	52.4	80	80	88	14	4.0	KH25B2V34	210

6000 PSI Series

1/2	12	M 8	5/16-18 UNC	23.5	22	97	17	112	18.2	40.5	55	45	60	10	1.1	KH12B2V62	420
3/4	20	M10	3/8-16 UNC	39.5	39	128	21	187	23.8	50.8	70	70	80	14	2.8	KH20B2V63	420
1	25	M12	7/16-16 UNC	42.0	46	138	19	187	27.8	57.2	80	80	88	14	4.0	KH25B2V64	420

¹⁾ Pressure shown = Item deliverable

The pressure specification PN for quarter turn ball valves applies to the design factor 1.5 (according DIN 3230 T5 and ISO 5208).

$$\frac{PN \text{ (bar)}}{10} = PN \text{ (MPa)}$$

Materials:

Body made of steel, coating DIN 50938-FE/A/T4, ball of hard chrome plated carbon steel, stem of zinc plated steel.

Seals:

Ball seat of POM (e.g. Delrin), stem seal of NBR (e.g. Perbunan).

Applications:

Suitable for petroleum-based hydraulic fluid, lubricants and fuel oil. For air applications suitable up to 100 bar.

Temperature range:

-10 up to +100° C

Order code suffixes			
Material	Suffix surface and material	Example	Standard sealing material (no additional suffix needed)
Steel, zinc plated, Cr(VI)-free	CF	KH12B2V32CFX	POM / NBR
Steel	DIN 50938-FE//A/T4	KH12B2V32X	POM / NBR

KH-B3V-S Ball valve with SAE Flange connection

SAE Flange / Ball valve 2/2 way steel
(ISO 6162-1/-2)

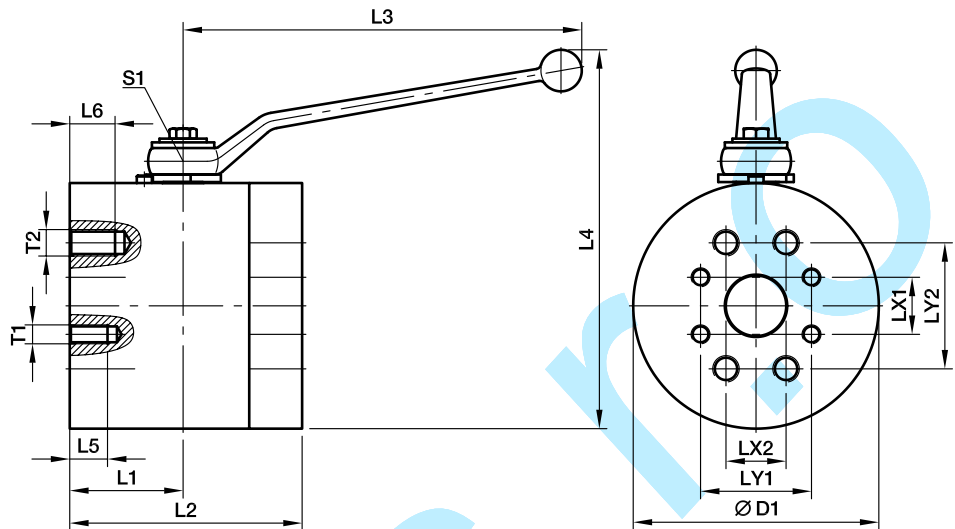

3000 PSI Series / 6000 PSI Series

Nom. flange size									3000 PSI Connection					6000 PSI Connection					Weight (steel) kg/piece	Order code*	PN (bar) ¹⁾	
SAE (in)	ISO (DN)	D1	L1	L2	L3	L4	S1	T1		LX1	LY1	L5	PN	T2		LX2	LY2	L6				PN
								UNC	UNC					UNC	UNC				UNC	UNC	UNC	
1 1/4	32	130	60	123	320	158.5	17	M12	7/16-14	30.2	58.7	27	276	M14	1/2-13	31.8	66.7	24	420	11.3	KH32B3V35	420
1 1/2	40	140	61	126	320	168.5	17	M12	1/2-13	35.7	69.9	25	207	M16	5/8-11	36.5	79.4	26	420	13.1	KH40B3V36	420
2	50	160	79	158	320	178.5	17	M12	1/2-13	42.8	77.8	25	207	M20	3/4-10	44.4	96.8	34	420	21.2	KH50B3V38	420

¹⁾ Pressure shown = Item deliverable

The pressure specification PN for quarter turn ball valves applies to the design factor 1.5 (according DIN 3230 T5 and ISO 5208).

$$\frac{PN \text{ (bar)}}{10} = PN \text{ (MPa)}$$

Materials:

Body made of steel, coating DIN 50938-FE/A/T4, ball of hard chrome plated carbon steel, stem of zinc plated steel.

Seals:

Ball seat of POM (e.g. Delrin), stem seal of NBR (e.g. Perbunan).

Applications:

Suitable for petroleum-based hydraulic fluid, lubricants and fuel oil. For air applications suitable up to 100 bar.

Temperature range:

-10 up to +100° C

Order code suffixes			
Material	Suffix surface and material	Example	Standard sealing material (no additional suffix needed)
Steel, zinc plated, Cr(VI)-free	CF	KH32B3V35CFX	POM / NBR
Steel	DIN 50938-FE//A/T4	KH32B3V35X	POM / NBR

KH-A-S Ball valve with SAE Flange adapter connection

SAE Flange / Ball valve 2/2 way steel
(ISO 6162-1/-2)

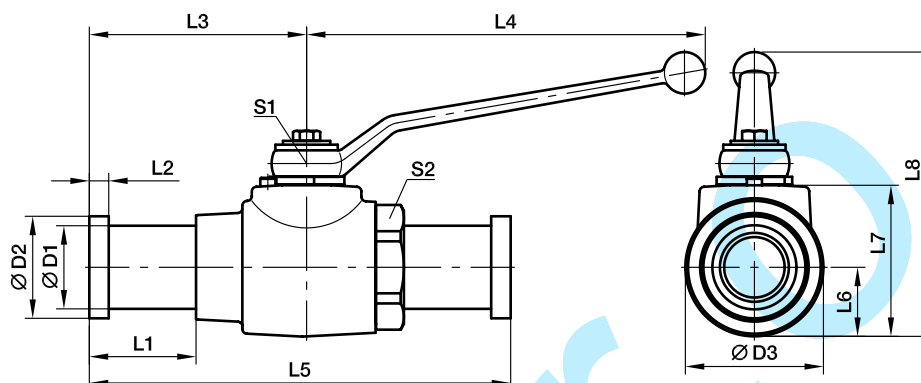

3000 PSI Series

Nom. flange size		D1	D2	D3	L1	L2	L3	L4	L5	L6	L7	L8	S1	S2	O-ring	Weight (steel) kg/piece	Order code*	PN (bar) ¹⁾ S
SAE (in)	ISO (DN)																	
1/2	12	24	30.2	35	42.0	6.7	75.5	112	151.0	17.0	40	92	10	32	18.66×3.53	0.9	KH12A32	350
3/4	20	32	38.1	45	43.0	6.7	81.0	187	162.0	24.0	55	113	14	41	25.00×3.53	1.7	KH20A33	315
1	25	38	44.4	55	38.9	8.0	89.0	187	178.0	26.0	60	118	14	50	32.92×3.53	2.5	KH25A34	315
1 1/4	32	43	50.8	73	40.3	8.0	99.0	227	190.5	36.5	80	155	17	60	37.70×3.53	3.1	KH32A35	276
1 1/2	40	50	60.3	85	58.3	8.0	115.5	227	231.0	42.5	90	165	17	70	47.22×3.53	4.3	KH40A36	207
2	50	62	71.4	99	50.9	9.5	116.0	227	232.0	49.5	104	179	17	85	56.74×3.53	5.8	KH50A38	207

6000 PSI Series

1/2	12	24	31.7	35	42.0	7.7	75.5	112	151.0	17.0	40	92	10	32	18.66×3.53	1.0	KH12A62	420
3/4	20	32	41.3	45	49.0	8.8	87.0	187	174.0	24.0	55	113	14	46	25.00×3.53	1.9	KH20A63	315
1	25	38	47.6	55	49.0	9.5	99.0	187	198.0	26.0	60	118	14	50	32.92×3.53	2.8	KH25A64	315
1 1/4	32	44	54.0	73	56.5	10.3	115.0	227	223.0	36.5	80	155	17	60	37.70×3.53	3.3	KH32A65	315
1 1/2	40	51	63.5	85	83.5	12.6	140.5	227	281.0	42.5	90	165	17	70	47.22×3.53	4.8	KH40A66	315
2	50	67	79.4	99	93.0	12.6	158.0	227	316.0	49.5	104	179	17	85	56.74×3.53	7.4	KH50A68	315

¹⁾Pressure shown = Item deliverable

The pressure specification PN for quarter turn ball valves applies to the design factor 1.5 (according DIN 3230 T5 and ISO 5208).

$$\frac{PN \text{ (bar)}}{10} = PN \text{ (MPa)}$$

Materials:

Body made of steel, coating DIN 50938-FE/A/T4, ball of hard chrome plated carbon steel, stem of zinc plated steel.

Seals:

Ball seat of POM (e.g. Delrin), stem seal of NBR (e.g. Perbunan).

Applications:

Suitable for petroleum-based hydraulic fluid, lubricants and fuel oil. For air applications suitable up to 100 bar.

Temperature range:

-10 up to +100° C

Order code suffixes			
Material	Suffix surface and material	Example	Standard sealing material (no additional suffix needed)
Steel, zinc plated, Cr(VI)-free	CF	KH12A63CFX	POM / NBR
Steel	DIN 50938-FE//A/T4	KH12A63X	POM / NBR

KH-A-S-71 Ball valve with SAE Flange adapter connection

SAE Flange / Ball valve 2/2 way stainless steel (ISO 6162-1/-2)

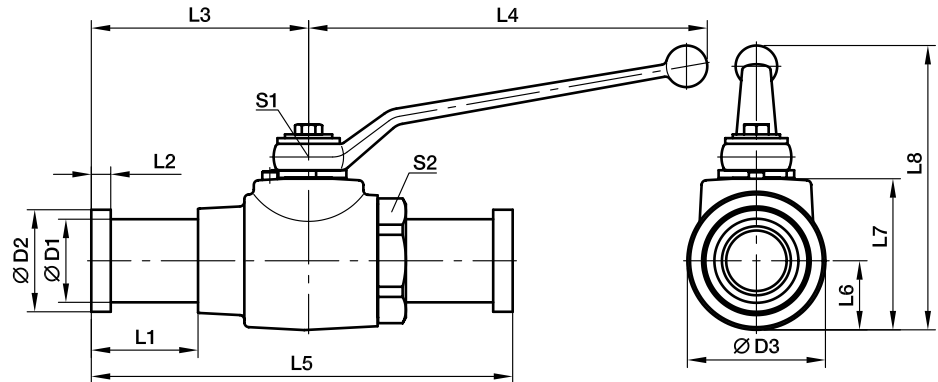

3000 PSI Series

Nom. flange size		D1	D2	L	L1	L2	L3	B	H	H1	H2	SW	SW1	O-ring	Order code*	PN (bar) S
SAE (in)	ISO (DN)															
1/2	12	24.0	176.0	42.0	6.8	55	45	45.0	21.0	49.5	32	10	28	18.64×3.53	KH12A3271	350
3/4	20	31.5	197.0	43.0	6.8	65	65	65.0	31.0	70.0	46	14	29	24.99×3.53	KH20A3371	350
1	25	38.0	200.0	38.9	8.0	71	75	75.0	38.0	80.0	50	14	29	32.92×3.53	KH25A3471	315
1 1/4	32	43.0	190.5	40.3	8.0	86	100	93.2	45.0	99.0	70	19	23	37.69×3.53	KH32A3571	250
1 1/2	40	50.0	236.5	58.3	8.0	92	110	104.4	52.2	110.0	80	19	23	47.22×3.53	KH40A3671	200
2	50	62.0	242.0	50.9	9.6	97	125	119.4	59.7	125.0	95	19	23	56.74×3.53	KH50A3871	160

6000 PSI Series

1/2	12	24.0	176.0	42.0	7.8	55	45	45.0	21.0	49.5	32	10	28	18.64×3.53	KH12A6271	400
3/4	20	32.0	209.0	49.0	8.8	65	65	65.0	31.0	70.0	46	14	29	24.99×3.53	KH20A6371	400
1	25	38.0	220.0	49.0	9.5	71	75	75.0	38.0	80.0	50	14	29	32.92×3.53	KH25A6471	400
1 1/4	32	44.0	223.0	56.5	10.3	86	100	93.2	45.0	99.0	70	19	23	37.69×3.53	KH32A6571	400
1 1/2	40	51.0	287.0	83.5	12.6	92	110	104.4	52.2	110.0	80	19	23	47.22×3.53	KH40A6671	400
2	50	67.0	327.0	93.5	12.6	97	125	119.4	59.7	125.0	95	19	23	56.74×3.53	KH50A6871	400

The pressure specification PN for quarter turn ball valves applies to the design factor 1.5 (according DIN 3230 T5 and ISO 5208)

Hand lever belongs to the scope of supply
Stainless steel (1.4571)

Body: Stainless steel
Switching ball: Stainless steel
Control shaft: Stainless steel
Switching ball sealing: POM
Control shaft sealing: FKM

Order code suffixes		
Material	Suffix surface and material	Example
Stainless steel	none	KH12A6271

KH-B4V-S Ball valve with SAE Flange connection ISO 6162 (1/2)

SAE flanges / ball valve 2/2-ways

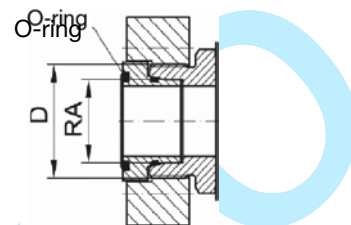
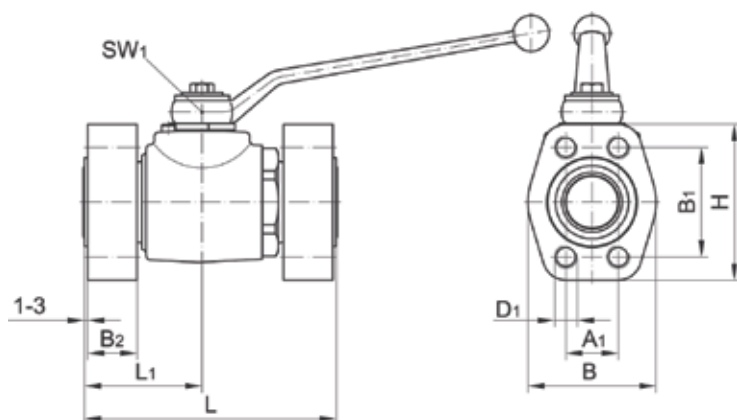

Port connection	DN	Thread D	RA	D1	A1	B1	B2	L	L1	B	H	O-ring	Weight kg	Order code	PN (bar) S
SAE flanges ISO 6162-1	12*	M 24×1.5	16	M 8	17.5	38.1	20	103	51.5	46	54	18.64×3.53	1.2	KH12B4V3M	350
	20*	M 36×2.0	25	M10	22.3	47.6	20	125	62.5	52	65	24.99×3.53	2.0	KH20B4V3M	350
	25*	M 42×2.0	30	M10	26.2	52.4	21	138	69.0	59	70	32.92×3.53	2.7	KH25B4V3M	315
	32	M 52×2.0	38	M10	30.2	58.7	24	153	71.5	73	79	37.69×3.53	3.8	KH32B4V3M	250
	40/32	M 52×2.0	38	M12	35.7	69.9	30	153	71.5	83	94	47.22×3.53	4.9	KH40/32B4V3M	200
Studs with solderless tube fittings DIN 2353 heavy series ISO 8434-1	12*	M 24×1.5	16	5/16-18 UNC	17.5	38.1	20	103	51.5	46	54	18.64×3.53	1.2	KH12B4V3U	350
	20*	M 36×2.0	25	3/8-16 UNC	22.3	47.6	20	125	62.5	52	65	24.99×3.53	2.0	KH20B4V3U	350
	25*	M 42×2.0	30	3/8-16 UNC	26.2	52.4	21	138	69.0	59	70	32.92×3.53	2.7	KH25B4V3U	315
	32	M 52×2.0	38	7/16-14 UNC	30.2	58.7	24	153	71.5	73	79	37.69×3.53	3.8	KH32B4V3U	250
	40/32	M 52×2.0	38	1/2-13 UNC	35.7	69.9	30	153	71.5	83	94	47.22×3.53	4.9	KH40/32B4V3U	200
SAE-clearance groove ISO 6162-2	12*	M 24×1.5	16	M 8	18.2	40.5	20	103	51.5	48	56	18.64×3.53	1.4	KH12B4V6M	400
	20*	M 36×2.0	25	M10	23.8	50.8	22	125	62.5	60	71	24.99×3.53	2.8	KH20B4V6M	400
	25*	M 42×2.0	30	M12	27.8	57.2	24	138	69.0	70	81	32.92×3.53	3.1	KH25B4V6M	400
	32	M 52×2.0	38	M12	31.8	66.6	30	153	71.5	78	95	37.69×3.53	4.3	KH32B4V6M	400
	40/32	M 52×2.0	38	M16	36.5	79.3	33	153	71.5	95	113	47.22×3.53	5.5	KH40/32B4V6M	400
Studs with solderless tube fittings DIN 2353 heavy series ISO 8434-1	12*	M 24×1.5	16	5/16-18 UNC	18.2	40.5	20	103	51.5	48	56	18.64×3.53	1.4	KH12B4V6U	400
	20*	M 36×2.0	25	3/8-16 UNC	23.8	50.8	22	125	62.5	60	71	24.99×3.53	2.8	KH20B4V6U	400
	25*	M 42×2.0	30	7/16-14 UNC	27.8	57.2	24	138	69.0	70	81	32.92×3.53	3.1	KH25B4V6U	400
	32	M 52×2.0	38	1/2-13 UNC	31.8	66.6	30	153	71.5	78	95	37.69×3.53	4.3	KH32B4V6U	400
	40/32	M 52×2.0	38	5/8-11 UNC	36.5	79.3	33	153	71.5	95	113	47.22×3.53	5.5	KH40/32B4V6U	400

*)Case in block construction

For the flanges see catalogue part N

Special types on request

Body:	Steel	Steel
Switching ball:	Steel/chromium plated	Steel/chromium plated
Control shaft:	Steel	Steel
Switching ball sealing:	POM	POM
Control shaft sealing:	NBR	FKM

Order code suffixes			
Material	Suffix surface and material	Example	Standard sealing material (no additional suffix needed)
Steel, zinc plated, Cr(VI)-free	CF	KH12B4V3MCFX	POM / NBR
Steel	DIN 50938-FE//A/T4	KH12B4V3MX	POM / NBR

KH-B5V-S Ball valve with flange connection DIN EN 1092-1

Steel/DIN/rotatable

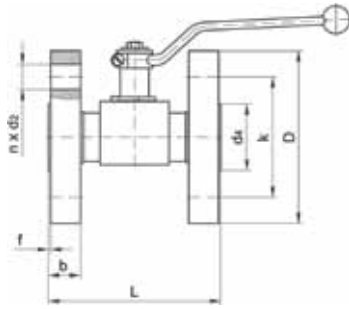

DN 10-DN25

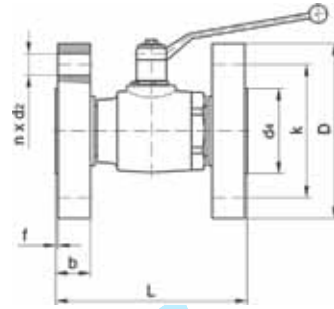

DN 32-DN50

Port connection	DN	D	b	k	d4	f	n	Number d2	L	Weight kg	Order code
PN 25 PN 40	10	90	16	60	40	2	4	14	130	2.1	KH10B5V40
	15	95	16	65	45	2	4	14	130	2.7	KH15B5V40
	20	105	18	75	58	2	4	14	150	3.8	KH20B5V40
	25	115	18	85	68	2	4	14	160	4.9	KH25B5V40
	32	140	18	100	78	2	4	18	180	7.0	KH32B5V40
	40	150	18	110	88	3	4	18	200	8.9	KH40B5V40
PN 63	50	165	20	125	102	3	4	18	230	12.2	KH50B5V40
	10	100	20	70	40	2	4	14	130	2.9	KH10B5V63
	15	105	20	75	45	2	4	14	130	3.5	KH15B5V63
	25	140	24	100	68	2	4	18	160	7.6	KH25B5V63
PN 100	40	170	26	125	88	3	4	22	200	12.6	KH40B5V63
	50	180	26	135	102	3	4	22	230	15.3	KH50B5V63
	10	100	20	70	40	2	4	14	130	2.9	KH10B5V100
	15	105	20	75	45	2	4	14	130	3.5	KH15B5V100
PN 160	25	140	24	100	68	2	4	18	160	7.6	KH25B5V100
	40	170	26	125	88	3	4	22	200	12.6	KH40B5V100
	50	195	28	145	102	3	4	26	230	17.9	KH50B5V100
	10	100	20	70	40	2	4	14	130	2.9	KH10B5V160
PN 250	15	105	20	75	45	2	4	14	130	3.5	KH15B5V160
	25	140	24	100	68	2	4	18	160	7.6	KH25B5V160
	40	170	28	125	88	3	4	22	200	13.2	KH40B5V160
	50	195	30	145	102	3	4	26	230	18.7	KH50B5V160
PN 320	10	125	24	85	40	2	4	18	130	5.0	KH10B5V250
	15	130	26	90	45	2	4	18	130	6.2	KH15B5V250
	25	150	28	105	68	2	4	22	160	9.5	KH25B5V250
	40	185	34	135	88	3	4	26	200	17.2	KH40B5V250
	50	200	38	150	102	3	8	26	230	22.6	KH50B5V250
PN 400	10	125	24	85	40	2	4	18	130	5.0	KH10B5V320
	15	130	26	90	45	2	4	18	130	6.2	KH15B5V320
	25	160	34	115	68	2	4	22	160	12.5	KH25B5V320
	40	195	38	145	88	3	4	26	200	20.5	KH40B5V320
	50	210	42	160	102	3	8	26	230	26.4	KH50B5V320
PN 400	10	125	28	85	40	2	4	18	210	6.0	KH10B5V400
	15	145	30	100	45	2	4	22	210	9.0	KH15B5V400
	25	180	38	130	68	2	4	26	230	17.4	KH25B5V400
	40	220	48	165	88	3	4	30	260	31.9	KH40B5V400
	50	235	52	180	102	3	8	30	300	38.9	KH50B5V400

flange connection dimensions: DIN EN 1092-1 (DIN 2501-1)
 sizes PN 25 – PN 320: DIN EN 558-1 series 1 (DIN 3202-1-F1)
 sizes PN 400: DIN EN 558-1 series 2 (DIN 3202-1-F2)
 special types on request

Body:	Steel	Steel	Steel
Switching ball:	Steel/chromium plated	steel/chromium plated	Steel/chromium plated
Control shaft:	Steel	Steel	Steel
Switching ball sealing:	POM	POM	PTFE-Comp. 3
Control shaft sealing:	NBR	FKM	FKM

Order code suffixes			
Material	Suffix surface and material	Example	Standard sealing material (no additional suffix needed)
Steel, zinc plated, Cr(VI)-free	CF	KH10B5V40CFX	POM / NBR
Steel	DIN 50938-FE//A/T4	KH10B5V40X	POM / NBR

KHBLOCK 2/2-way ball valves for block structure

Steel – DN6 – DN50

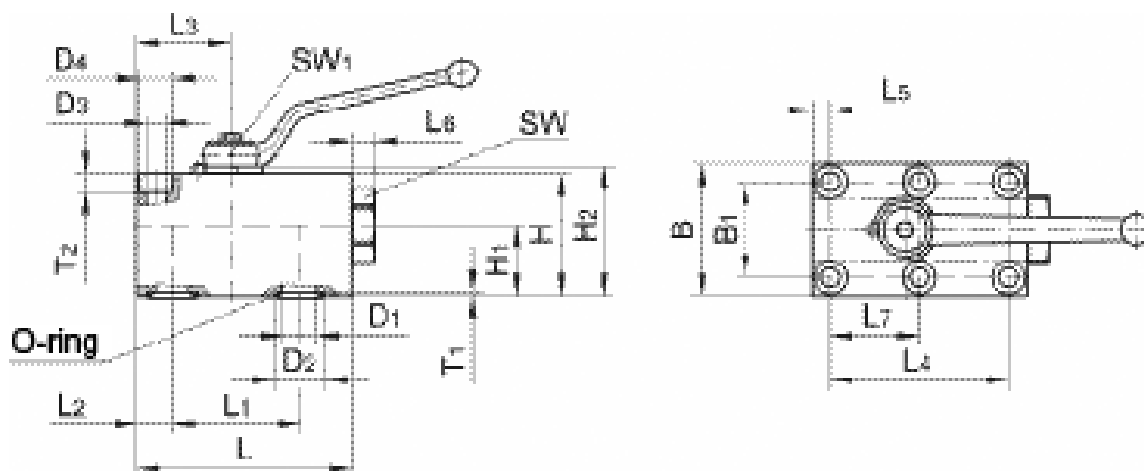

Port connection	DN	L	L1	L2	L3	L4	L5	L6	L7	B	B1	H	H1	H2	T1	T2	D1	D2	D3	D4	SW	SW1	Weight kg	Order code
Body flange with O-ring sealing	6	59	35	8.5	23.5	35	8.5	4.5	17.5	40	27	35	20.0	37.5	1.8	6.8	6.0	12.0	6.4	11	24	7	0.58	KHBLOCKDN6
	10	73	44	10.0	29.0	55	7.5	7.0	27.5	55	40	45	24.5	48.5	1.8	8.0	9.5	15.0	8.4	-	32	8	1.17	KHBLOCKDN10
	12	98	58	16.0	42.5	83	7.5	10.0	41.5	60	45	55	32.0	58.5	1.8	8.0	15.5	25.0	8.4	-	36	10	2.25	KHBLOCKDN12
	20	117	69	20.0	52.0	97	10.0	12.0	48.5	70	51	70	39.0	74.0	2.7	11.0	20.0	30.0	10.5	17	-	14	4.00	KHBLOCKDN20
	25	138	81	24.0	62.0	115	10.0	7.0	57.5	80	60	80	46.0	84.0	2.7	11.0	24.0	35.0	10.5	17	50	14	5.82	KHBLOCKDN25
	32	165	96	29.0	75.0	136	12.0	11.0	68.0	100	78	100	56.6	104.5	2.7	12.0	32.0	40.0	13.0	19	70	17	10.97	KHBLOCKDN32
	40	175	112	28.5	84.5	112	28.5	25.0	56.0	130	95	100	52.6	104.5	2.7	17.5	38.0	48.5	17.0	26	-	17	15.25	KHBLOCKDN40
50	215	136	38.0	106.0	136	38.0	25.0	68.0	150	112	110	55.1	114.5	2.7	20.0	48.0	55.5	21.0	33	-	17	23.20	KHBLOCKDN50	

	DN	D1	E1	E2	E3	E4	E5	E6	E7	E8	M	O-ring
General tolerances DIN ISO 2768 Surfaces DIN EN ISO 4287	6	6.0	35	35.0	50.5	-	8.5	13.5	20.0	17.5	M 6	7.5x2.5
	10	9.5	44	52.5	63.0	2.5	10.0	20.0	27.5	25.0	M 8	10.5x2.5
	12	15.5	58	74.5	82.0	8.5	16.0	22.5	30.0	33.0	M 8	20.5x2.5
	20	20.0	69	87.0	97.0	10.0	20.0	25.5	35.0	38.5	M10	23.5x3.5
	25	24.0	81	101.0	114.0	14.0	24.0	30.0	40.0	43.5	M10	28.5x3.5
	32	32.0	96	119.0	136.0	17.0	29.0	39.0	50.0	51.0	M12	33.5x3.5
	40	38.0	112	112.0	146.5	-	28.5	47.5	65.0	56.0	M16	42.0x3.5
50	48.0	136	136.0	177.0	-	38.0	56.0	75.0	68.0	M20	49.0x3.5	

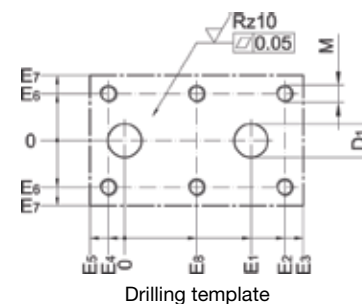

Body: Steel Steel
 Switching ball: Steel/chromium plated Steel/chromium plated
 Control shaft: Steel Steel
 Body sealing: NBR FKM
 Switching ball sealing: POM POM
 Control shaft sealing: NBR FKM

Standard surface: bronzed
 For Cr(VI)-free please add CF
 Example: **KHBLOCKDN6CFX**

DV Shut-off valve PN 10 – Casing DIN 3512

EO 24° cone end / EO 24° cone end

(with internal threaded spindle)

For cold and warm water* up to 80°C, compressed air, mineral oils and fuel oils types EL and L, 6 bar and up to 80°C.

The pressure specification PN for hand-operated shut-off valves applies to the design factor 1,5 (according to DIN 3230 T5 and ISO 5208).

Caution!

Please note the admissible pressure ratings for the EO-tube ends.

DVAE

EO tube end ♂ male BSPP

DVAA

male BSPP ⇐ EO tube end

DV-valves with male BSPP thread on request.

*Indicate type of water or additive if any

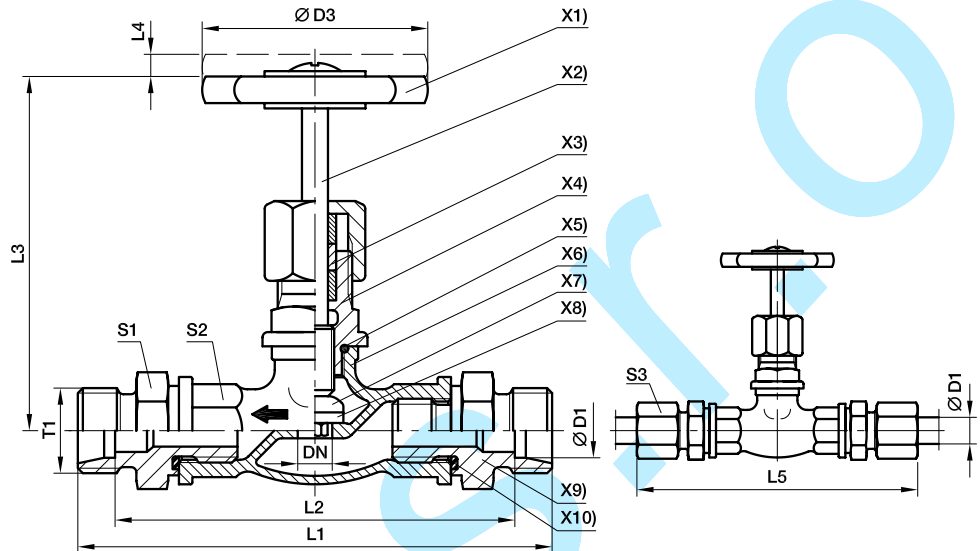

- X1) **Hand wheel:** material: Polyamid
- X2) **Spindle:** material: Brass 2.0401
- X3) **Stuffing boxpacking:** PTFE Compound
- X4) **Haed piece:** material: Brass 2.0401
- X5) **Sealing:** O-ring NBR (e. g. Perbunan)
- X6) **Casing:** material: Brass 2.0340.02
- X7) **Valve cone:** material: Brass 2.0401
- X8) **Shut-off sealing:** NBR (e.g. Perbunan)
- X9) **Male stud fitting:** material: Brass 2.0540
- X10) **Sealing:** Eolastic-sealing NBR (e.g. Perbunan)

Series	D1	T1	DN	D3	L1	L2	L3	L4	L5	S1	S2	S3	Weight g/1 piece	Order code*	PN (bar) ¹⁾ without surface
L ³⁾	06	M 12×1.5	5	50	102	88	63	7	117	22	21	14	313	DV06LX	10
	08	M 14×1.5	6	50	102	88	63	7	117	22	21	17	305	DV08LX	10
	10	M 16×1.5	8	50	104	90	63	7	119	22	21	19	308	DV10LX	10
	12	M 18×1.5	10	50	104	90	63	7	119	22	21	22	304	DV12LX	10
	15	M 22×1.5	12	50	107	93	65	8	123	27	25	27	426	DV15LX	10
	18	M 26×1.5	16	50	109	94	67	8	126	27	25	32	434	DV18LX	10
	22	M 30×2.0	20	60	123	108	67	8	140	32	32	36	670	DV22LX	10
	28	M 36×2.0	25	60	140	125	95	10	158	41	38	41	1030	DV28LX	10
	35	M 45×2.0	32	70	166	145	102	10	188	50	47	50	1640	DV35LX	10

¹⁾ Pressure shown = item deliverable

³⁾ L = light series

$$\frac{PN \text{ (bar)}}{10} = PN \text{ (MPa)}$$

Delivery without nut and ring. Information on ordering complete fittings or alternative sealing materials see page 17.

*Please add the suffixes below according to the material/surface required.

Order code suffixes			
Material	Suffix surface and material	Example	Standard sealing material (no additional suffix needed)
Brass 2.0340.02	without	DV06LX	PTFE / NBR

LD Shut-off valve PN 40

EO 24° cone end / EO 24° cone end

(with internal threaded spindle)

For hydraulic oil, mineral, oil, fuel oil, Diesel, water* etc. Temperature up to 150°C. For steam up to 10 bar. For compressed air up to 35 bar on request. CS DIN 86501 Rg.-N.

The pressure specification PN for hand-operated shut-off valves applies to the design factor 1,5 (according DIN 3230 T5 and ISO 5208).

Caution!

Please note the admissible pressure ratings for the EO-tube ends.

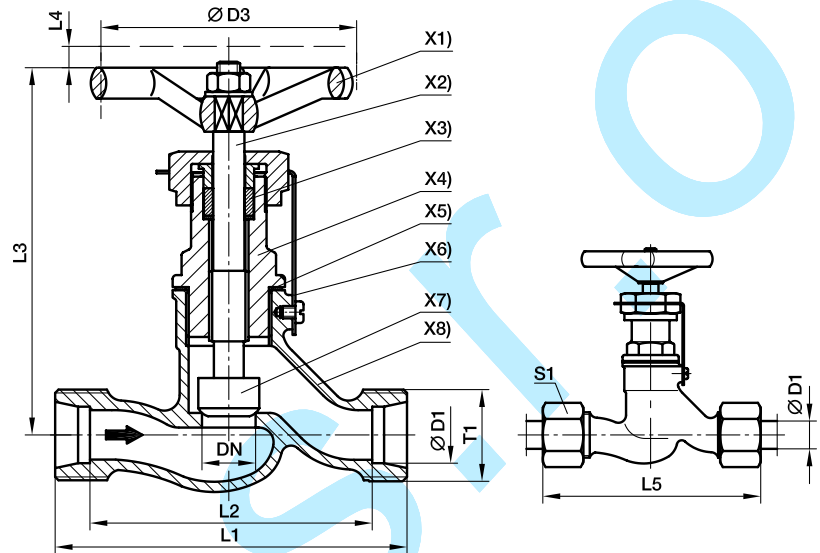

- X1) **Hand wheel:** Plastic material typ 74 according to DIN 388 Form C
- X2) **Spindle:** with internal thread. Material: Cu Zn 35 Ni 2
- X3) **Stuffing box packing:** Graphite
- X4) **Head piece:** material: Cu Zn 39 Pb 3
- X5) **Sealing:** Copper ring
- X6) **Locking plates:** material: St. 37/zinc plated
- X7) **Valve cone:** loose tip material: Cu Zn 35 Ni 2
- X8) **Casing:** material: G-Cu Sn 5Zn Pb (Rg 5 according to DIN 1705)

EO-tube connection:

for **copper** tubes nuts, cutting and locking rings of brass

Attention:

for **steel** tubes: nuts, progressive rings of steel **specify when ordering**

We recommend pre-installation in hardened pre-installation body (see assembly instructions)

Series	D1	T1	DN	D3	L1	L2	L3	L4	L5	S1	Weight g/1 piece	Order code*	PN (bar) ¹⁾ without surface
S ⁴⁾	10	M 18x1.5	6	63	60	45	98	7	77	22	383	LD10SX	40
	12	M 20x1.5	8	63	64	49	98	7	81	24	401	LD12SX	40
	14	M 22x1.5	10	63	70	54	98	7	89	27	417	LD14SX	40
	16	M 24x1.5	12	80	84	67	110	9	103	30	631	LD16SX	40
	20	M 30x2.0	16	80	90	69	110	9	112	36	688	LD20SX	40
	25	M 36x2.0	20	100	110	86	129	12	134	46	1191	LD25SX	40
	30	M 42x2.0	25	100	120	93	129	12	146	50	1322	LD30SX	40
	38	M 52x2.0	32	100	140	108	158	12	169	60	2268	LD38SX	40

¹⁾ Pressure shown = item deliverable

⁴⁾ S = heavy series

$$\frac{PN \text{ (bar)}}{10} = PN \text{ (MPa)}$$

Delivery without nut and ring. Information on ordering complete fittings or alternative sealing materials see page P54.

*Please add the **suffixes** below according to the material/surface required.

Order code suffixes			
Material	Suffix surface and material	Example	Standard sealing material (no additional suffix needed)
Gunmetal (Rg 5) 2.1096	without	LD10SX	Graphit / Metal

VDHA High pressure valve

EO tube end / EO tube end

with internal threaded spindle and body of low grade forged stainless steel
The pressure specification PN for hand-operated shut-off valves applies to the design factor 1,5 (according DIN 3230 T5 and ISO 5208).

Caution!
Please note the admissible pressure ratings for the EO-tube ends.

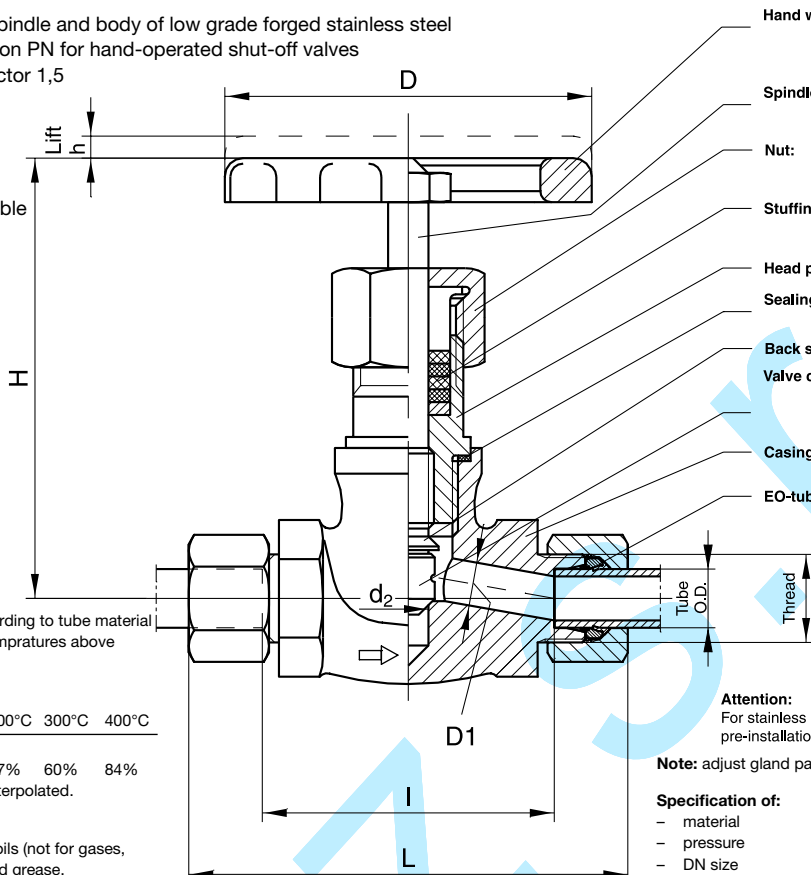

- Hand wheel:** Aluminium die casting GD-AL Si 8 Cu 3
Operating position: completely opened or closed.
- Spindle:** Material 1.4021
- Nut:** Material 1.0718
- Stuffing box packing:** GA 24 (Graphit)
- Head piece:** Material 1.0460
- Sealing:** between casing and head piece, material-no. 2.4066
- Back sealing:** against head piece
- Valve cone:** hardened loose tip material 1.4122. For VDHA 30-PS and 38-PS material 1.0460 forged with Cr 17
- Casing:** forged. Material No. 1.4104
- EO-tube connection:** Nuts and progressive rings of steel for the assembly of steel tubes. For stainless steel tubes material no. 1.4571 or 1.4541 and temperatures above 120°C progressive rings and nuts of 1.4571 are to used. (Please specify when ordering)

Temperatures up to 400°C according to tube material (consider pressure drop with temperatures above 50°C)

Required pressure reductions

temperature	50°C	100°C	200°C	300°C	400°C
pressure reductions	6%	15%	37%	60%	84%

Intermediate values are to be interpolated.

Applications:
For water, steam, hot and cold oils (not for gases, oxygen etc.) on mineral oil based grease.
For compressed air up to 50°C. For corrosive media, acids, fire resistant fluid etc.

Attention:
For stainless steel tubes always pre-assembly in hardened pre-installation body (see assembly instructions)

Note: adjust gland packing prior to initial working period.

- Specification of:**
- material
 - pressure
 - DN size
 - identification mark on hand wheel.

Series	D1	PN (bar)	DN	Thread	d2	H	L	I	h	D	Weight g/1 piece	With Nut and Ring	
												Dry Technology EO-2	PSR steel
S ⁴⁾	06	630	4	M 14×1.5	9.5	120	95	66	6	100	891	VDHA06ZS	VDHA06S
	08	630	5	M 16×1.5	9.5	120	95	66	6	100	917	VDHA08ZS	VDHA08S
	10	630	7	M 18×1.5	9.5	120	97	65	6	100	937	VDHA10ZS	VDHA10S
	12	630	8	M 20×1.5	9.5	120	97	65	6	100	940	VDHA12ZS	VDHA12S
	14	630	10	M 22×1.5	9.5	120	119	84	6	100	1194	VDHA14ZS	VDHA14S
	16	400	11	M 24×1.5	9.5	120	119	83	6	100	1209	VDHA16ZS	VDHA16S
	20	400	13	M 30×2.0	11.0	120	122	79	6	100	1292	VDHA20ZS	VDHA20S
	25	400	17	M 36×2.0	12.0	143	154	106	9	125	2013	VDHA25ZS	VDHA25S
	30	250	19	M 42×2.0	22.5	164	156	103	12	125	2596	VDHA30ZS	VDHA30S
	38	250	25	M 52×2.0	26.5	198	179	118	12	180	4972	VDHA38ZS	VDHA38S

¹⁾ Pressure shown = item deliverable
⁴⁾ S = heavy series

$$\frac{PN(\text{bar})}{10} = PN(\text{MPa})$$



WV Alternating valve

EO 24° cone end / EO 24° cone end / EQ 24° cone end

These valves permit the passage of flow from either inlet 1 or 2 to the outlet port whilst shutting of the inlet port not in use. The shutting off, of an inlet is achieved by a floating ball bearing which moves by the pressure of the flow.

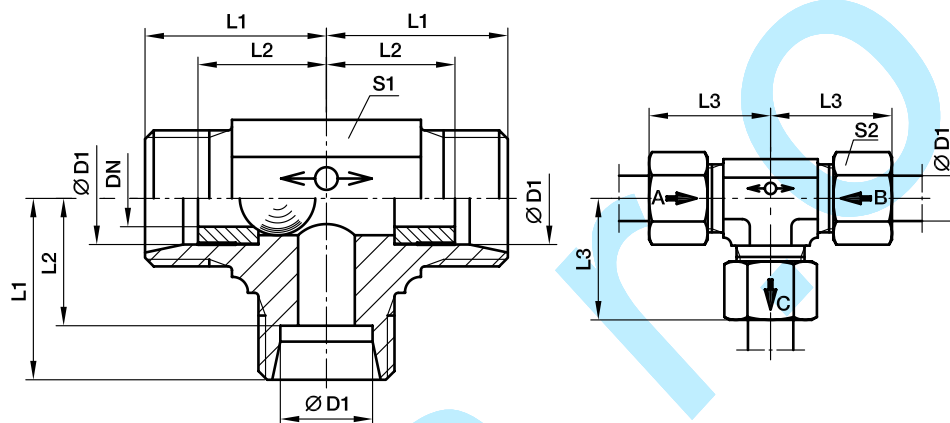

Material: steel
Surface finish: Cr(VI)-free.

Valves are not recommended for compressed air and gases.
WV-valves are not to be used in connection with weld nipples, swivel nuts etc. where there is no contact with a shoulder stop in the inner cone.

Temperature range without pressure reductions: -40°C up to +120°C.

Recommended fitting position as shown in the picture.

Leakage rate for alternating valves hydraulic test with test pressure = P_{max} : approx. 20 drops (test period of 1 minute).

Directions of flow:

$D_1 \rightarrow D_3 = D_2$ closed
 $D_2 \rightarrow D_3 = D_1$ closed

Series	D1	T1	DN	L1	L2	L3	S1	S2	Weight g/1 piece	Order code*	PN (bar) ¹⁾ CF
L ³⁾	8	M 14×1.5	4.5	21	14	29	14	17	53	WV08LOMD	160
	10	M 16×1.5	6.0	22	15	30	17	19	73	WV10LOMD	160
	12	M 18×1.5	7.5	24	17	32	19	22	96	WV12LOMD	160
	15	M 22×1.5	10.0	28	21	36	19	27	134	WV15LOMD	160

¹⁾Pressure shown = item deliverable

³⁾L = light series

$\frac{PN \text{ (bar)}}{10} = PN \text{ (MPa)}$

Delivery without nut and ring. Information on ordering complete fittings or alternative sealing materials see page P56.

*Please add the **suffixes** below according to the material/surface required.

Order code suffixes			
Material	Suffix surface and material	Example	Standard sealing material (no additional suffix needed)
Steel, zinc plated, Cr(VI)-free	CF	WV08LOMDCF	Steel ball

ELA air-bleed valves

Hydraulic systems can effectively be bled with ELA air-bleed valves.

Easily installed – maintenance-free – almost unlimited service life – simple – safe – reliable – efficient.
The system can be operated immediately. No control irregularities due to air contamination of the pressure medium.
Cost saving, as non-productive de-aeration time is saved.

Air bleed between: – opening pressure 0.05 bar
– closing pressure ≥ 0.5 bar

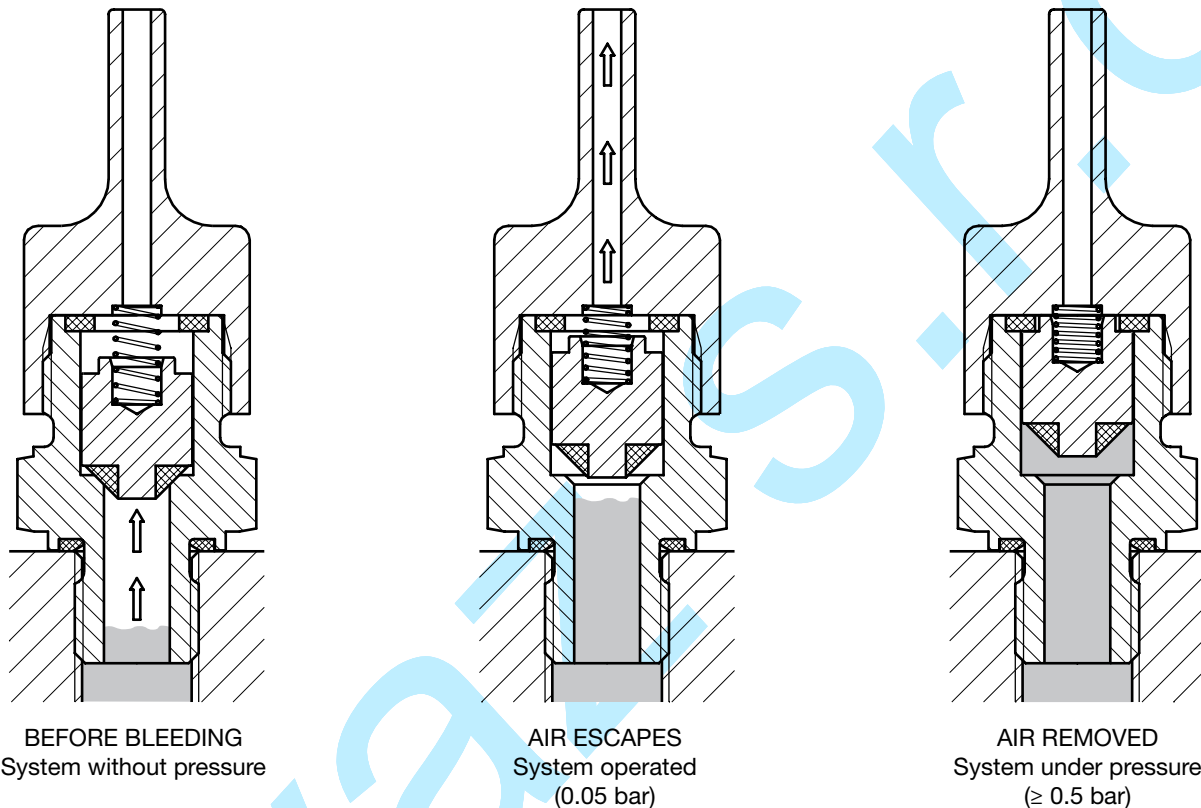

The principle of the air-bleed valve is based on the difference in behaviour of gases and liquids under pressure because of their dependence on viscosity. A piston, housed in the bore of the body with defined clearance, effects the opening and closing of the valve on start-up or shut-down of the system. On setting the system in operation, the accumulated air escapes until the liquid column of the pressure medium reaches the piston. The pressure of the liquid lifts the piston against the upper, high pressure seal, securely closing the air-vent (slight oil discharge may occur). When pressure is released the spring releases the piston reopening the air-vent, whereupon the procedure may be repeated. The special piston design prevents any intake of air in case of partial vacuum.

The air bleed valve should be connected vertical, at the highest point of the hydraulic system or in places where air accumulation may occur.

ELA air-bleed valves are available only for mineral oil based fluids, and within the temperature limits of -20°C to $+90^{\circ}\text{C}$.

ELA Air-bleed valves

Male BSPP thread with Eolastic seal

PN (bar)	Dry Technology Steel	Weight g/1 piece
400	ELA1/4EDCF	109

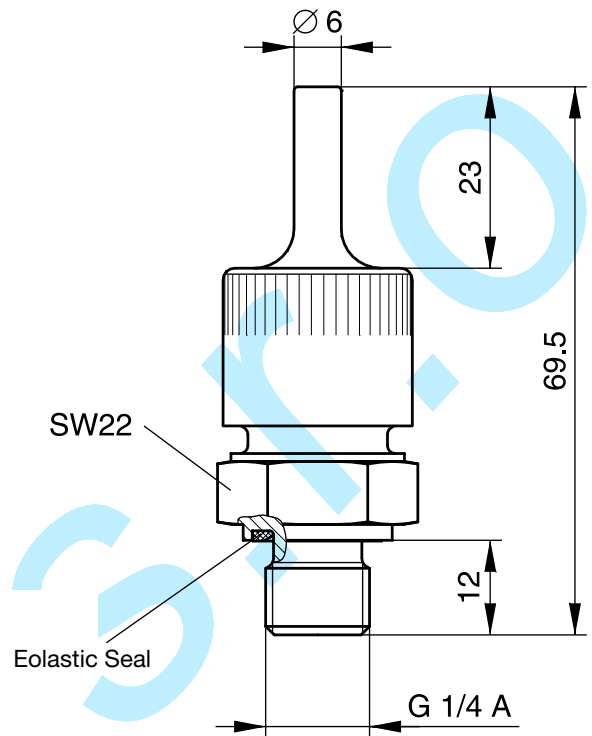

EO Swivel

PN (bar)	Dry Technology Steel	Weight g/1 piece
315	ELAE10LCF	125

